

SERVICE MANUAL



Model:

PDP4294LV1

Safety Precaution
Technical Specifications
Block Diagram
Circuit Diagram
Basic Operations & Circuit Description
Main IC Specifications
Product Specification of PDP Module
Trouble Shooting Manual of PDP Module
Spare Part List
Exploded View
If you forget your V-Chip Password
Software Upgrade

This manual is the latest at the time of printing, and does not include the modification which may be made after the printing, by the constant improvement of product.

Safety Precaution

 <div style="border: 1px solid black; padding: 5px; text-align: center;">CAUTION RISK OF ELECTRIC SHOCK DO NOT OPEN</div> 	<p>The lightning flash with arrowhead symbol, within an equilateral triangle, is intended to alert the user to the presence of uninsulated "dangerous voltage" within the product's enclosure that may be of sufficient magnitude to constitute a risk of electric shock to persons.</p> <p>The exclamation point within an equilateral triangle is intended to alert the user to the presence of important operating and maintenance (servicing) instructions in the literature accompanying the appliance.</p>
---	--

CAUTION: TO REDUCE THE RISK OF ELECTRIC SHOCK, DO NOT REMOVE COVER (OR BACK). NO USER-SERVICEABLE PARTS INSIDE. REFER SERVICING TO QUALIFIED SERVICE PERSONNEL ONLY.

PRECAUTIONS DURING SERVICING

- In addition to safety, other parts and assemblies are specified for conformance with such regulations as those applying to spurious radiation. These must also be replaced only with specified replacements.
Examples: RF converters, tuner units, antenna selection switches, RF cables, noise-blocking capacitors, noise-blocking filters, etc.
- Use specified internal Wiring. Note especially:
 - Wires covered with PVC tubing
 - Double insulated wires
 - High voltage leads
- Use specified insulating materials for hazardous live parts. Note especially:
 - Insulating Tape
 - PVC tubing
 - Spacers (insulating barriers)
 - Insulating sheets for transistors
 - Plastic screws for fixing micro switches
- When replacing AC primary side components (transformers, power cords, noise blocking capacitors, etc.), wrap ends of wires securely about the terminals before soldering.

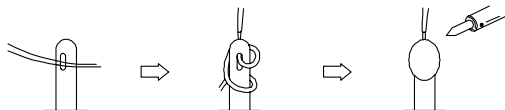

- Make sure that wires do not contact heat generating parts (heat sinks, oxide metal film resistors, fusible resistors, etc.)
- Check if replaced wires do not contact sharply edged or pointed parts.
- Make sure that foreign objects (screws, solder droplets, etc.) do not remain inside the set.

MAKE YOUR CONTRIBUTION TO PROTECT THE ENVIRONMENT

Used batteries with the ISO symbol



for recycling as well as small accumulators (rechargeable batteries), mini-batteries (cells) and starter batteries should not be thrown into the garbage can.

Please leave them at an appropriate depot.

WARNING:

Before servicing this TV receiver, read the **SAFETY INSTRUCTION** and **PRODUCT SAFETY NOTICE**.

SAFETY INSTRUCTION

The service should not be attempted by anyone unfamiliar with the necessary instructions on this apparatus. The following are the necessary instructions to be observed before servicing.

- An isolation transformer should be connected in the power line between the receiver and the AC line when a service is performed on the primary of the converter transformer of the set.
- Comply with all caution and safety related provided on the back of the cabinet, inside the cabinet, on the chassis or picture tube.
- To avoid a shock hazard, always discharge the picture tube's anode to the chassis ground before removing the anode cap.
- Completely discharge the high potential voltage of the picture tube before handling. The picture tube is a vacuum and if broken, the glass will explode.

5. When replacing a MAIN PCB in the cabinet, always be certain that all protective are installed properly such as control knobs, adjustment covers or shields, barriers, isolation resistor networks etc.
6. When servicing is required, observe the original lead dressing. Extra precaution should be given to assure correct lead dressing in the high voltage area.
7. Keep wires away from high voltage or high temperature components.
8. Before returning the set to the customer, always perform an AC leakage current check on the exposed metallic parts of the cabinet, such as antennas, terminals, screwheads, metal overlay, control shafts, etc., to be sure the set is safe to operate without danger of electrical shock. Plug the AC line cord directly to the AC outlet (do not use a line isolation transformer during this check). Use an AC voltmeter having 5K ohms volt sensitivity or more in the following manner.
Connect a 1.5K ohm 10 watt resistor paralleled by a 0.15 μ F AC type capacitor, between a good earth ground (water pipe, conductor etc.,) and the exposed metallic parts, one at a time. Measure the AC voltage across the combination of the 1.5K ohm resistor and 0.15 μ F capacitor. Reverse the AC plug at the AC outlet and repeat the AC voltage measurements for each exposed metallic part.

The measured voltage must not exceed 0.3V RMS.

This corresponds to 0.5mA AC. Any value exceeding this limit constitutes a potential shock hazard and must be corrected immediately.

The resistance measurement should be done between accessible exposed metal parts and power cord plug prongs with the power switch "ON". The resistance should be more than 6M ohms.

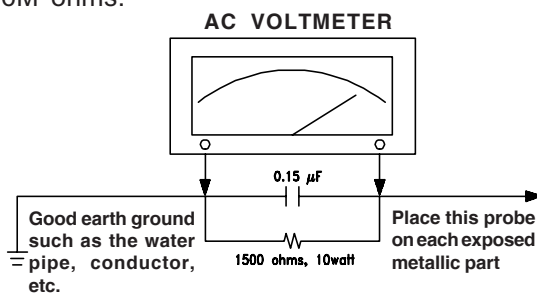

AC Leakage Current Check

PRODUCT SAFETY NOTICE

Many electrical and mechanical parts in this apparatus have special safety-related characteristics.

These characteristics are offer passed unnoticed by visual spection and the protection afforded by them cannot necessarily be obtained by using replacement components rates for a higher voltage, wattage, etc.

The replacement parts which have these special safety characteristics are identified by \triangle marks on the schematic diagram and on the parts list.

Before replacing any of these components, read the parts list in this manual carefully. The use of substitute replacement parts which do not have the same safety characteristics as specified in the parts list may create shock, fire, or other hazards.

9. Must be sure that the ground wire of the AC inlet is connected with the ground of the apparatus properly.

Technical Specifications		MODEL : <u>PDP4294LV1</u> 42" Plasma Display		
DATE FIRST ISSUED	ISSUE 1	RAISED BY	CHECKED BY	NUMBER OF PAGES 9

REVISIONS			
ISSUED	DATE	DESCRIPTION	RAISED BY :

SPECIFICATION AGREED :	SIGNATURE	DATE
R & D DEPARTMENT
COMMERCIAL DEPARTMENT
PRODUCTION DEPARTMENT
Q/A DEPARTMENT
CUSTOMER

SPECIFICATION APPROVED :	SIGNATURE :	DATE :

NOTE : Only documents stamped "Controlled Document" to be used for manufacture of production parts.

1. Standard Test Conditions

All tests shall be performed under the following conditions, unless otherwise specified.

- 1.1 Ambient light : 150ux (When measuring I_B , the ambient luminance $\cong 0.1\text{Cd/m}^2$)
- 1.2 Viewing distance : 50cm in front of PDP
- 1.3 Warm up time : 30 minutes
- 1.4 PDP Panel facing : no restricted
- 1.5 Measuring Equipment : PC, Chroma 2225 signal generator (with Chroma digital additional card) or equivalent, Minolta CA100 photometer
- 1.6 Magnetic field : no restricted
- 1.7 Control settings : Brightness, Contrast, Tint, Color set at Center(50)
- 1.8 Power input : 100~240Vac
- 1.9 Ambient temperature : $20^{\circ}\text{C} \pm 5^{\circ}\text{C}$ ($68^{\circ}\text{F} \pm 9^{\circ}\text{F}$)
- 1.10 Display mode : 31.5KHz/60Hz (Resolution 852 x 480)
- 1.11 Other conditions :
 - 1.11.1 With image sticking protection of PDP module, the luminance will descend by time on a same still screen and rapidly go down in 5 minutes. When measuring the color tracking and luminance of a same still screen, be sure to accomplish the measurement in one minute to ensure its accuracy.
 - 1.11.2 Due to the structure of PDP, the extra-high-bright same screen should not hold over 5 minutes for fear of branding on the panel.

ELECTRICAL CHARACTERISTICS**2. Power Input**

- 2.1 Voltage : 100 ~ 240VAC
- 2.2 Input Current : 3.5 / 1.5A
- 2.3 Maximum Inrush Current : <30 A (FOR AC110V ONLY)
Test condition : Measured when switched off for at least 20 mins
- 2.4 Frequency : 50Hz to 60Hz(±3Hz)
- 2.5 Power Consumption : ≤ 330W
Test condition : full white display with maximum brightness and contrast
- 2.6 Power Factor : Meets IEC1000-3-2
- 2.7 Withstanding voltage : 1.5kVac or 2.2kVdc for 1 sec

3. Display

- 3.1 Screen Size : 42" Plasma display
- 3.2 Aspect Ratio : 16:9
- 3.3 Pixel Resolution : 852x480
- 3.4 Peak Brightness : 1000 cd/m² (Panel module without filter)
- 3.5 Contrast Ratio (Dark room) : 3000:1 (Panel module without filter)
- 3.6 Viewing Angle : Over 160°
- 3.7 OSD language : English

4. Signal4.1 AV & Graphic input

- 4.1.1 TV standard : NTSC
- 4.1.2 TV Tuning system : PLL 181Ch
- 4.1.3 CATV : 125CH
- 4.1.4 Composite signal : CVBS
- 4.1.5 Y,C Signal : S-Video
- 4.1.6 Component signal : Y, Pb/Cb, Pr/Cr, HDTV compatible
- 4.1.7 Graphic I/P : Analog: D-sub 15pin detachable cable
Digital: DVI
- 4.1.8 PnP compatibility : DDC 1.0
- 4.1.9 I/P frequency : f_H: 31.5kHz to 60kHz/f_V: 56.25Hz to 75Hz (640x480 recommended)

4.2 Audio input
Audio I/P(L/Rx5) : 1 for DVI / D-Sub
1 for Y/ Pb/Pr
1 for Y/ Cb/Cr
1 for CVBS
1 for S-Video

4.3 Audio output
Audio O/P(L/Rx1) : Monitor out(L/R)

4.4 Other function : PIP, 16:9, 4:3, Zoom

5. Environment

5.1 Operating environment
5.1.1 Temperature : 5° to 33°C
5.1.2 Relative humidity: 20% to 85%(non-condensing)

5.2 Storage and Transport
5.2.1 Temperature : -20°C to 60°C(-4° to 140°F)
5.2.2 Relative humidity: 5% to 95%

6. Panel Characteristics

6.1 Type : LG V6
6.2 Size : 42", 1005mm(width)x597mm(height)x61mm(depth)±1 mm)
6.3 Aspect ratio : 16:9
6.4 Viewing angle : Over 160°
6.5 Resolution : 852x480
6.6 Weight : 14.8kg ±0.5 kg (Net)
6.7 Color : 16.77 million colors by combination of 8 bits R,G,B digital
6.8 Contrast : Average 60:1 (In a bright room with 150Lux at center)
Typical 3000:1 (In a dark room 1/25 White Window pattern at center).
6.9 Peak brightness : Typical 1000cd/m² (1/25 White Window)
6.10 Color Coordinate Uniformity : Contrast; Brightness and Color control at normal setting
Test Pattern : Full white pattern

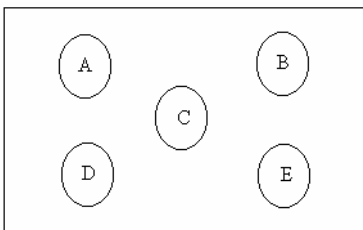

Average of point A,B,C,D and E +/- 0.01

6.11 Color temperature : Contrast at center (50); Brightness center (50);
Colortemperature set at Natural
x=0.285±0.02
y=0.293±0.02

6.12 Cell Defect Specifications
Subject to Panel supplier specification as appends.

7. Front Panel Control Button

- 7.1 CH Up / Down Button : Push the key to changing the channel up or down.
When selecting the item on OSD menu.
- Volume Up/ Down Button : Push the key to increase the volume up or down.
When selecting the adjusting item on OSD menu
increase or decrease the data-bar.
- Menu Button : Enter to the OSD menu.
- Input Select Button : Push the key to select the input signals source.
- 7.2 Stand by Button : Switch on main power, or switch off to enter power
Saving modes.
- 7.3 Main Power Switch : Turn on or off the unit.

8. OSD Function

- 8.1 Audio : Adjust or Select Volume; Bass; Treble; Balance; SRS; BBE; AVC;
Int./Ext. Speaker.
- 8.2 Picture : Adjust or Select Brightness; Contrast; Sharpness; Scaling (Picture
changes According to Fill or One to One.; DNR; Video Format;
More options for Y/Pb/Pr and VGA (H. Position, V. Position Phase,
Frequency)
- 8.3 OSD : Position; OSD H. Position; OSD V. Position; OSD Timeout;
OSD Background; Language.
- 8.4 Tools : Factory Reset; Source Scan; Blank Color; Turn Off Timer; Screen
Saver; Saver Mode.
- 8.5 TV : Edit Channels; Auto Fine Tune; Source.
- 8.6 CC-V Chip : TV Channel Blocking; Movie Blocking; Change Blocking Password;
Clear Password; CC Mode; CC Background.

9. Agency Approvals

Safety	UL60950
Emissions	FCC class B

10. Reliability

11.1 MTBF : 20,000 hours(Use moving picture signal at 25°C ambient)

11. Accessories : User manual x1, Remote control x1, Stand x1, Power cord x1, Battery x 2, Accessories box x 1.

12. Support the Signal Mode

The PDP can support the different from DVI or VGA Signal Mode in 24 kinds

NO.	Resolution	Horizontal Frequency (KHz)	Vertical Frequency (Hz)	Dot Clock Frequency (MHz)
1#	640 x400	31.47	70.08	25.17
2#	640 x400	37.90	85.00	31.5
3	640 x480	31.50	60.00	25.18
4	640 x480	35.00	67.00	30.24
5	640 x480	37.50	75.00	31.50
6	640 x480	37.86	72.81	31.50
7#	640 x480	43.30	85.00	36.00
8	800 x600	35.16	56.25	36.00
9	800 x600	37.90	60.32	40.00
10	800 x600	46.90	75.00	49.50
11	800 x600	48.08	72.19	50.00
12	800 x600	53.70	85.00	56.25
13	832 x624	49.00	75.00	57.27
14	1024 x768	48.40	60.00	65.00
15	1024 x768	56.50	70.00	75.00
16	1024 x768	60.00	75.00	78.75
17	1024 x768	68.70	85.00	94.50
18*	1152x864	54.53	60.00	80.37
19	1152x864	67.52	75.02	108.03
20*	1152x864	63.86	70.02	94.51
21	1280x1024	63.37	60.01	111.51
22	1280 x960	75.02	75.02	126.00
23	1280 x960	60.02	60.02	108.04
24#	1280x720	44.96	59.95	74.19

Note: DVI could not support * of signal mode.
VGA could not support # of signal mode.

- Press "DISPLAY" button to confirm the input signal format.

Note: Some data will be updated in five seconds if you change them.

13. Remote Function+

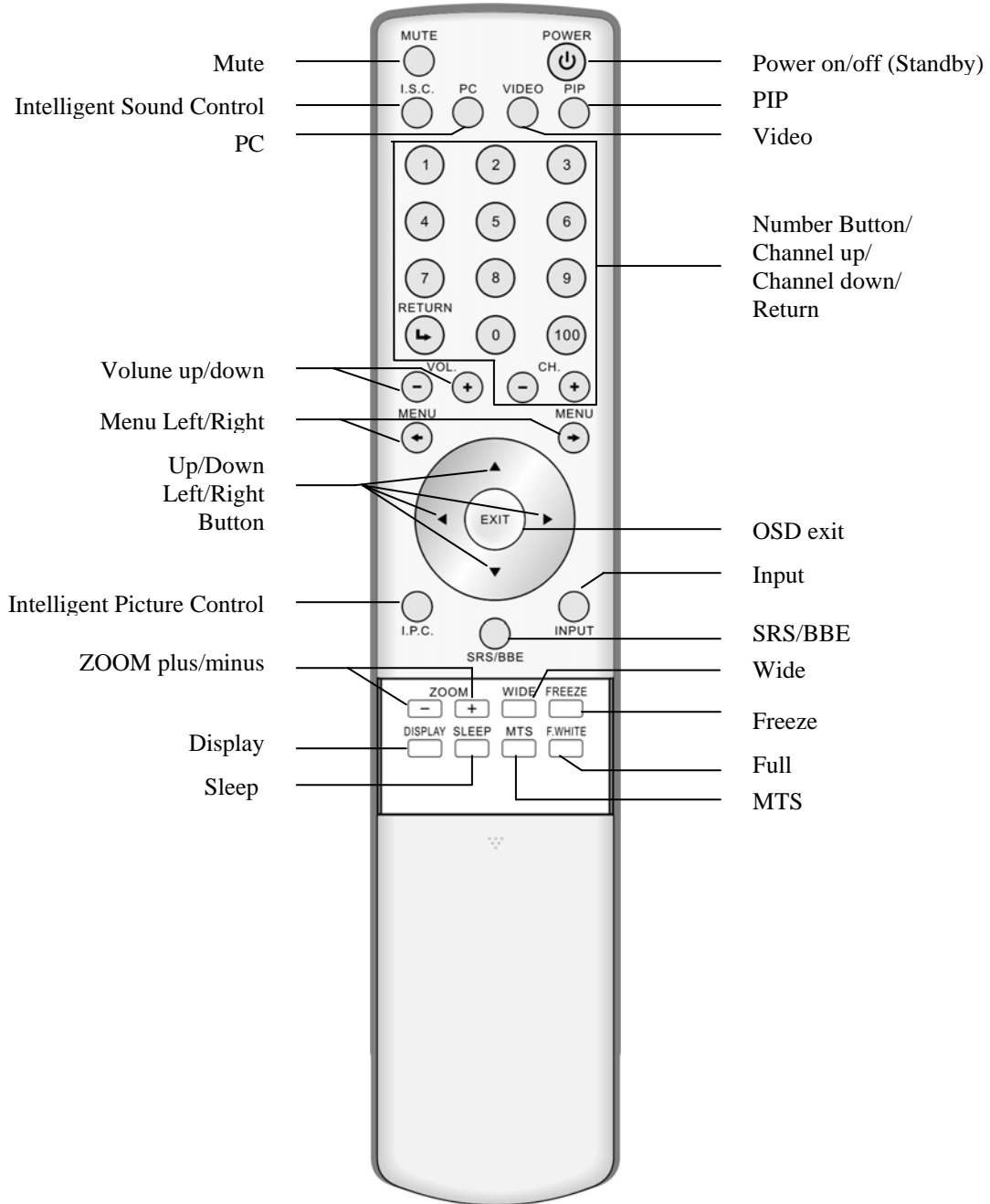

PHYSICAL CHARACTERISTICS**14. Power Cord**

Length : 1.8m nominal
Type : optional

15. Cabinet

15.1 Color : "Black" colour as defined by colour plaque reference number

15.2 Weight

Net weight : 73.9lbs (33.5kg)
Gross weight : 87.1lbs(39.5kg)

15.3 Dimensions(with stand)

Width : 45 inches (1140mm)
Height : 28-3/8 inches (720mm)
Depth : 11-4/8 inches (290mm)

Block Diagram

Product Specification of PDP Module

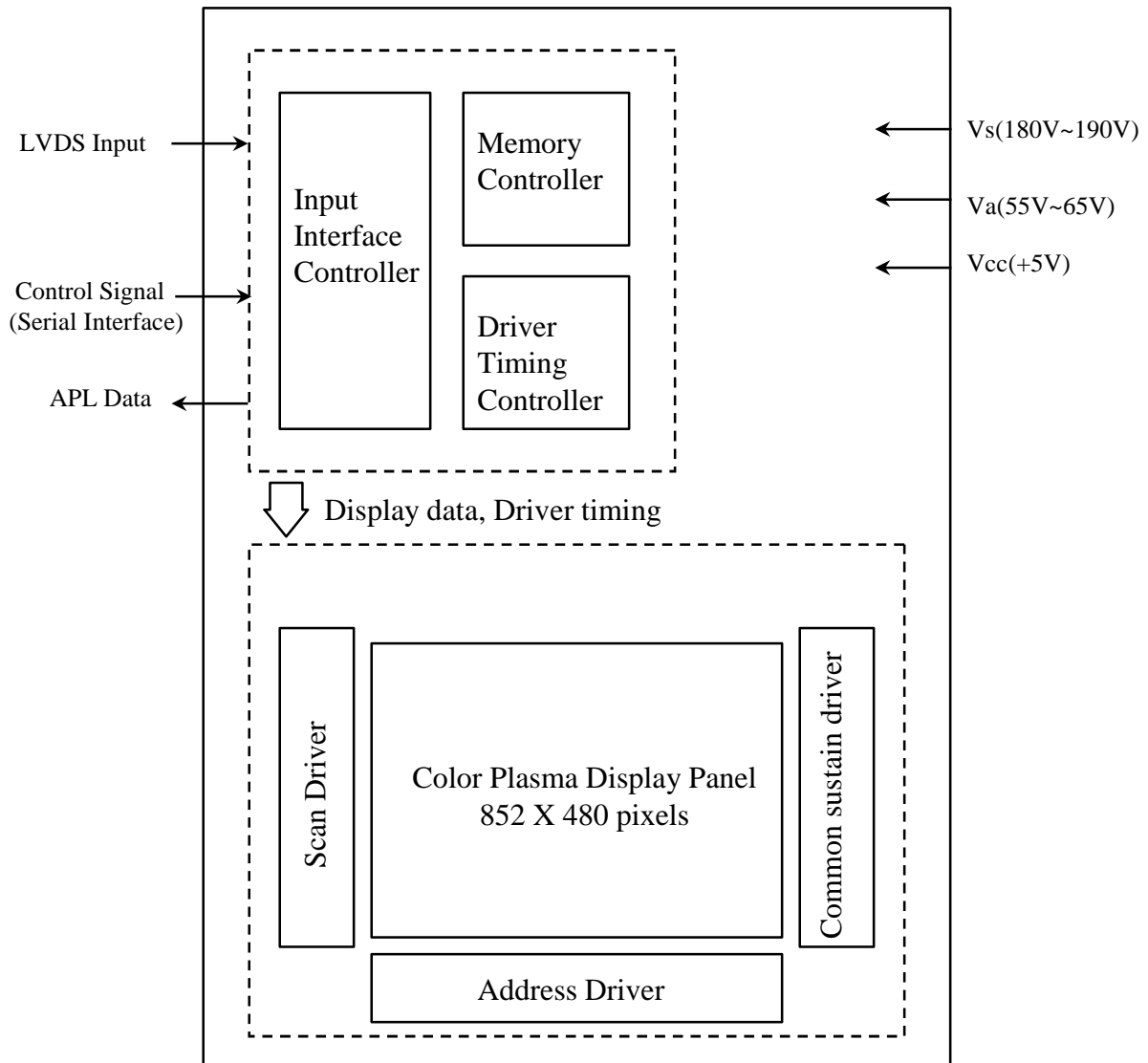

Applied Voltage level is specified at the time when Full-White pattern is displayed on the panel.

Block Diagram

MAIN/AUDIO BOARD

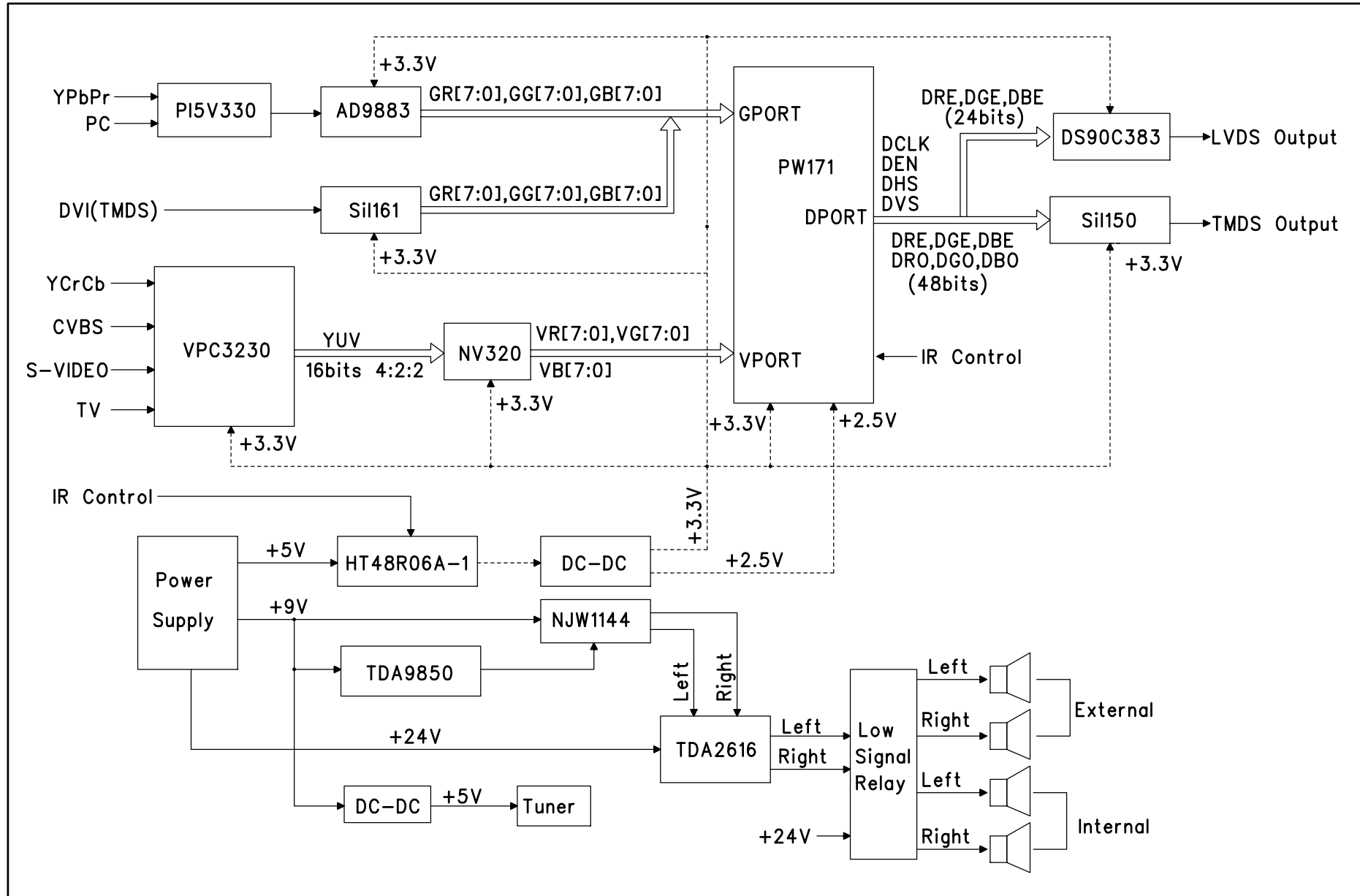

Circuit Diagram

- **Power supply board of PDP Module, DGP-420WXGA**
- **Power supply board of PDP Module, USP490M-42LP**
- **Main (Video) board**
- **Audio/Tuner board**
- **Keypad board**
- **Remote control receiver board**
- **External L/R Speakers board**
- **Remote control board**

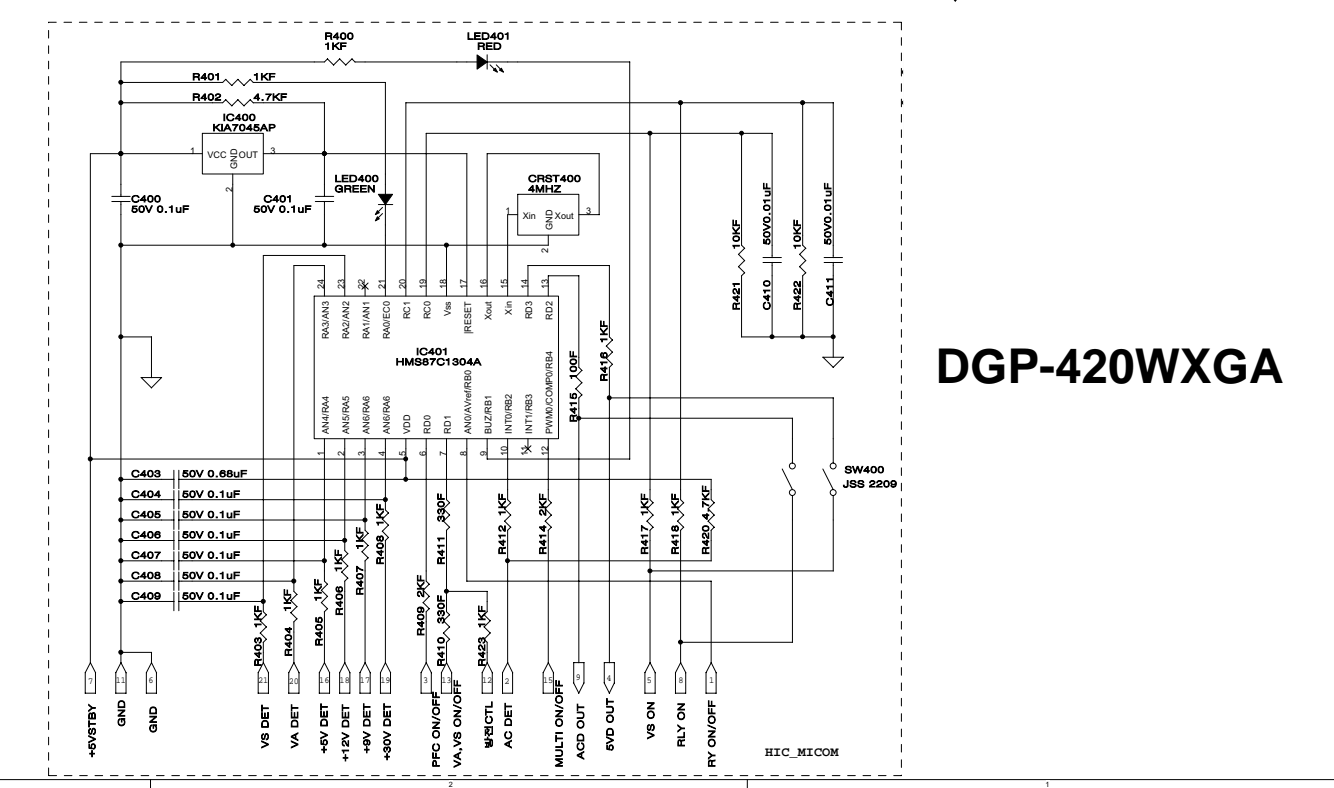
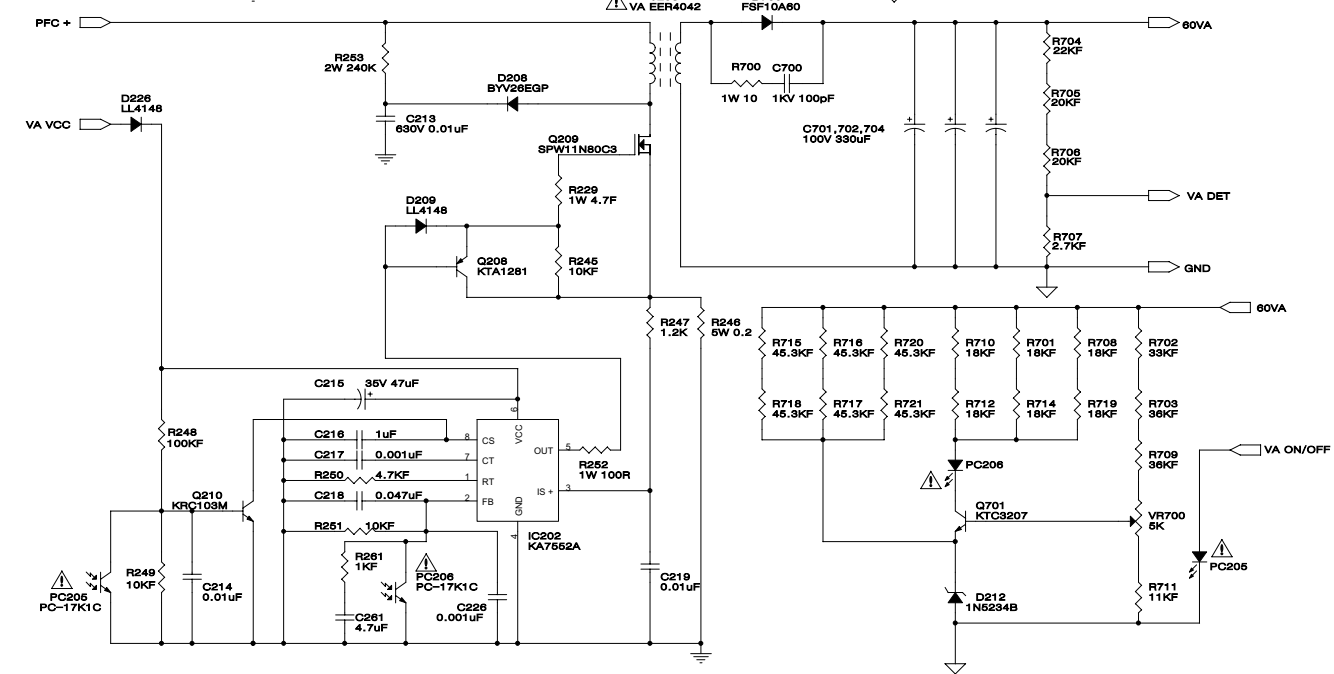
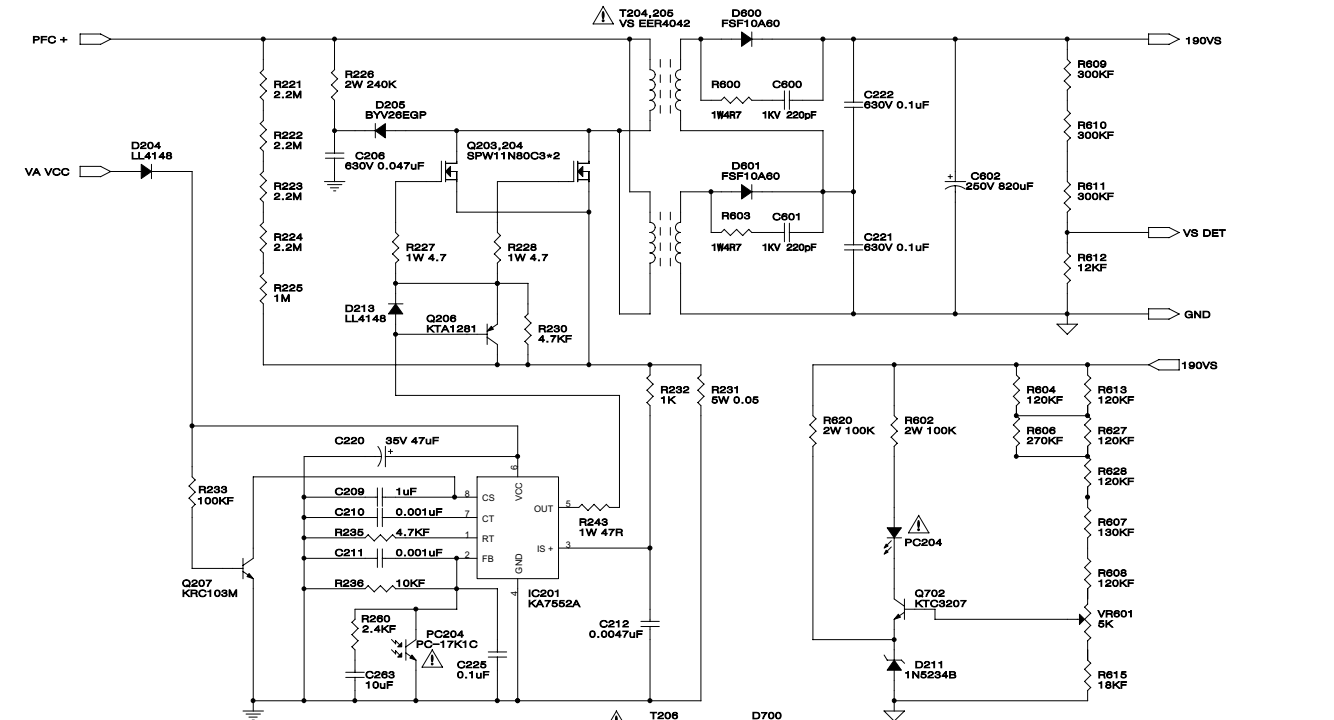
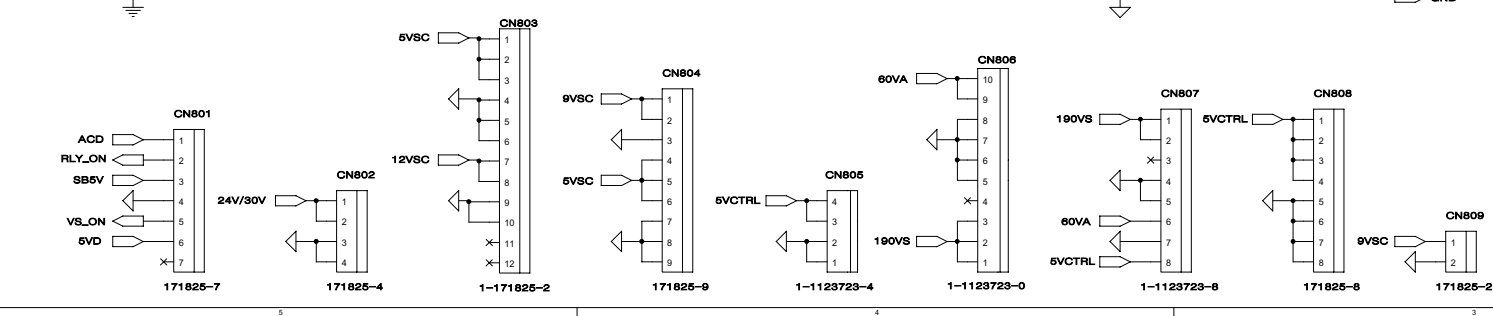
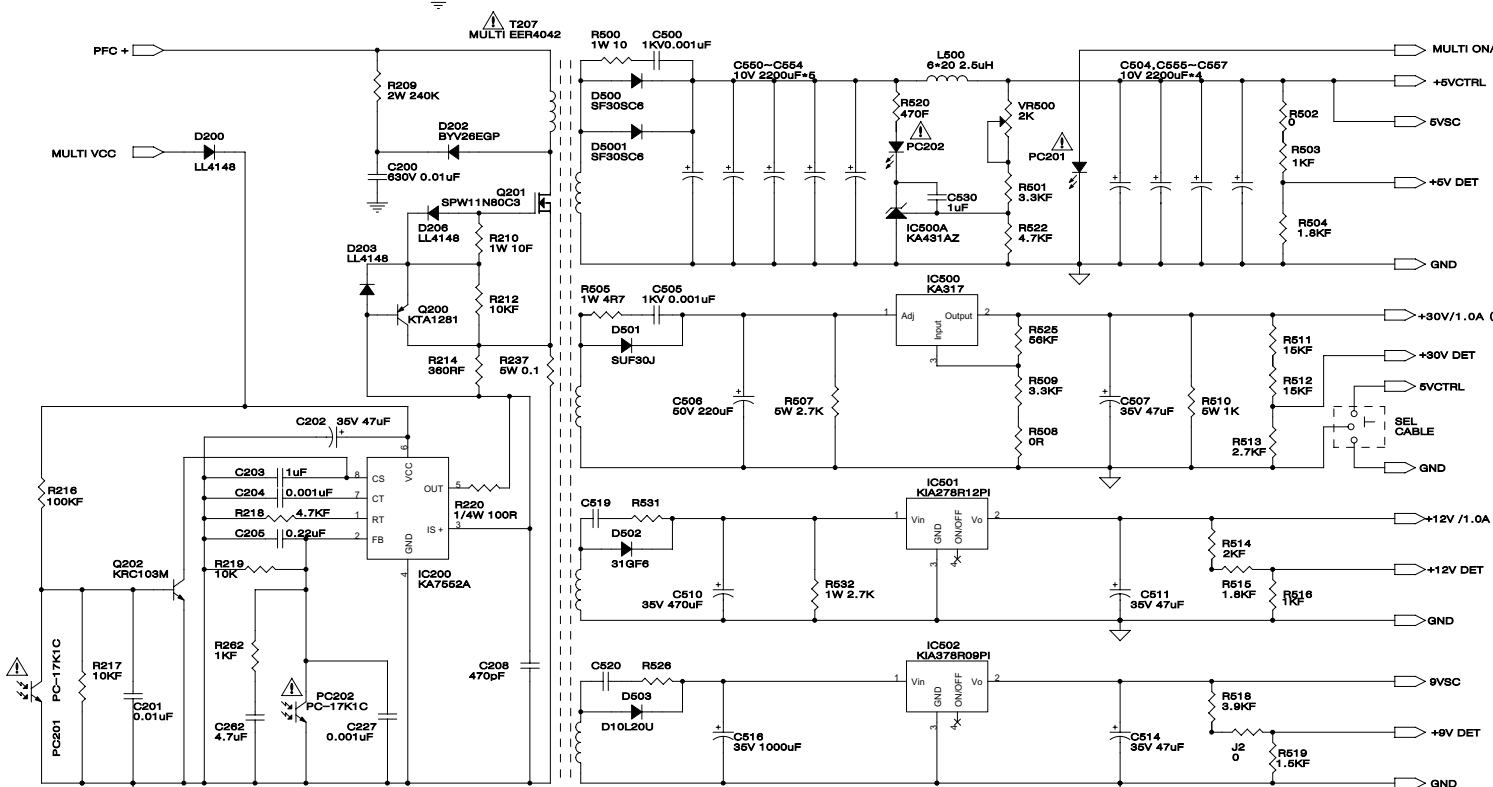
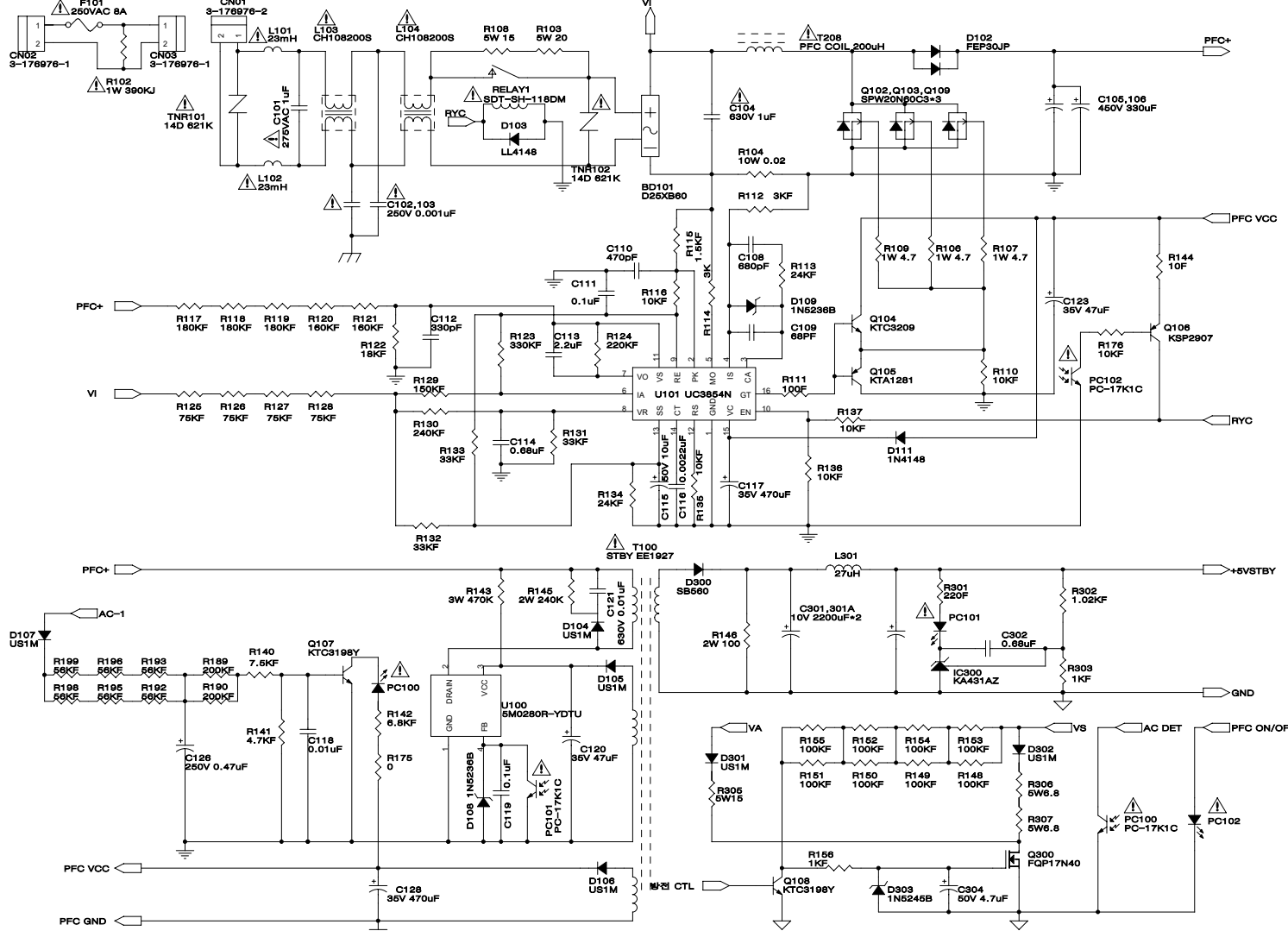

DGP-420WXGA

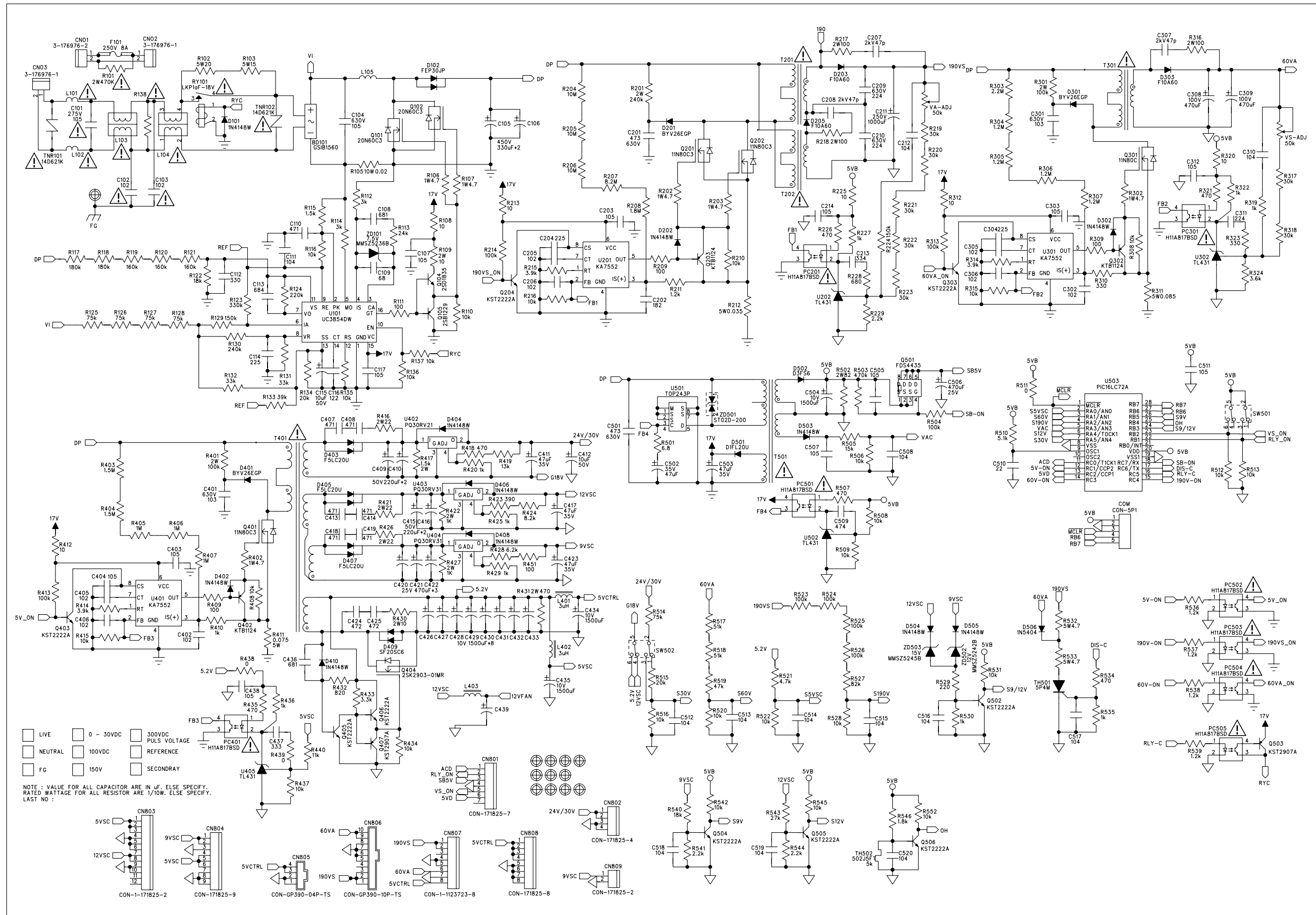

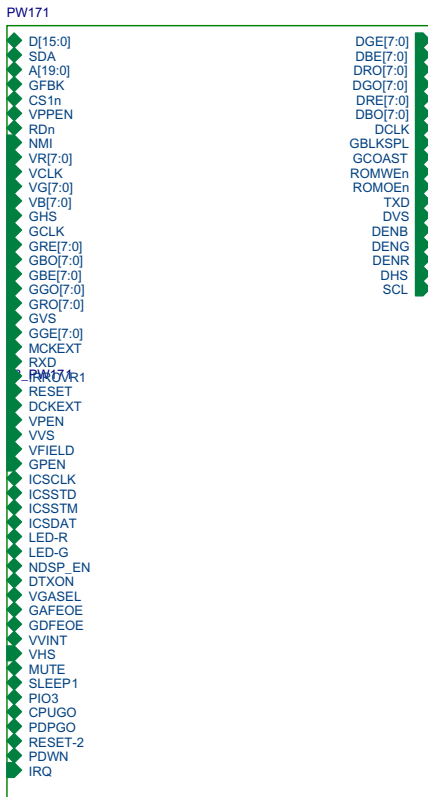
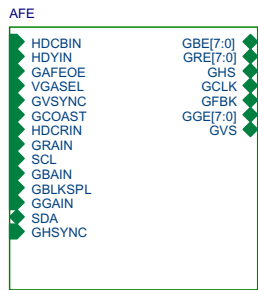
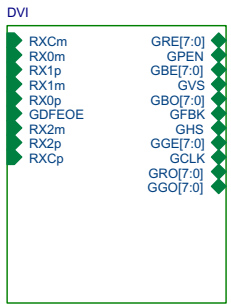
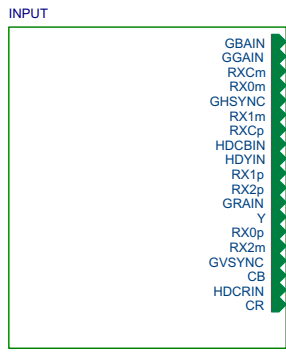

02_INPUT

03_DVI

04_AFE

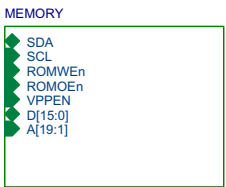
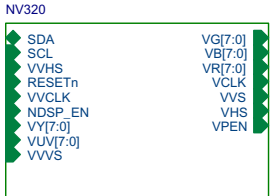
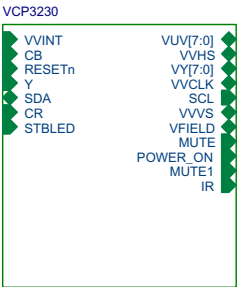

05_VCP3230

06_NV320

07_MEMORY

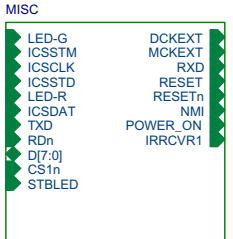
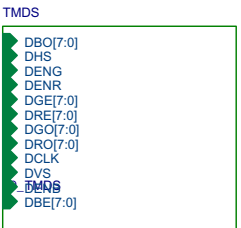

POWER

LVDS

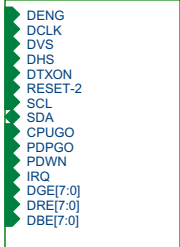

11_POWER

12_LVDS

10_MISC

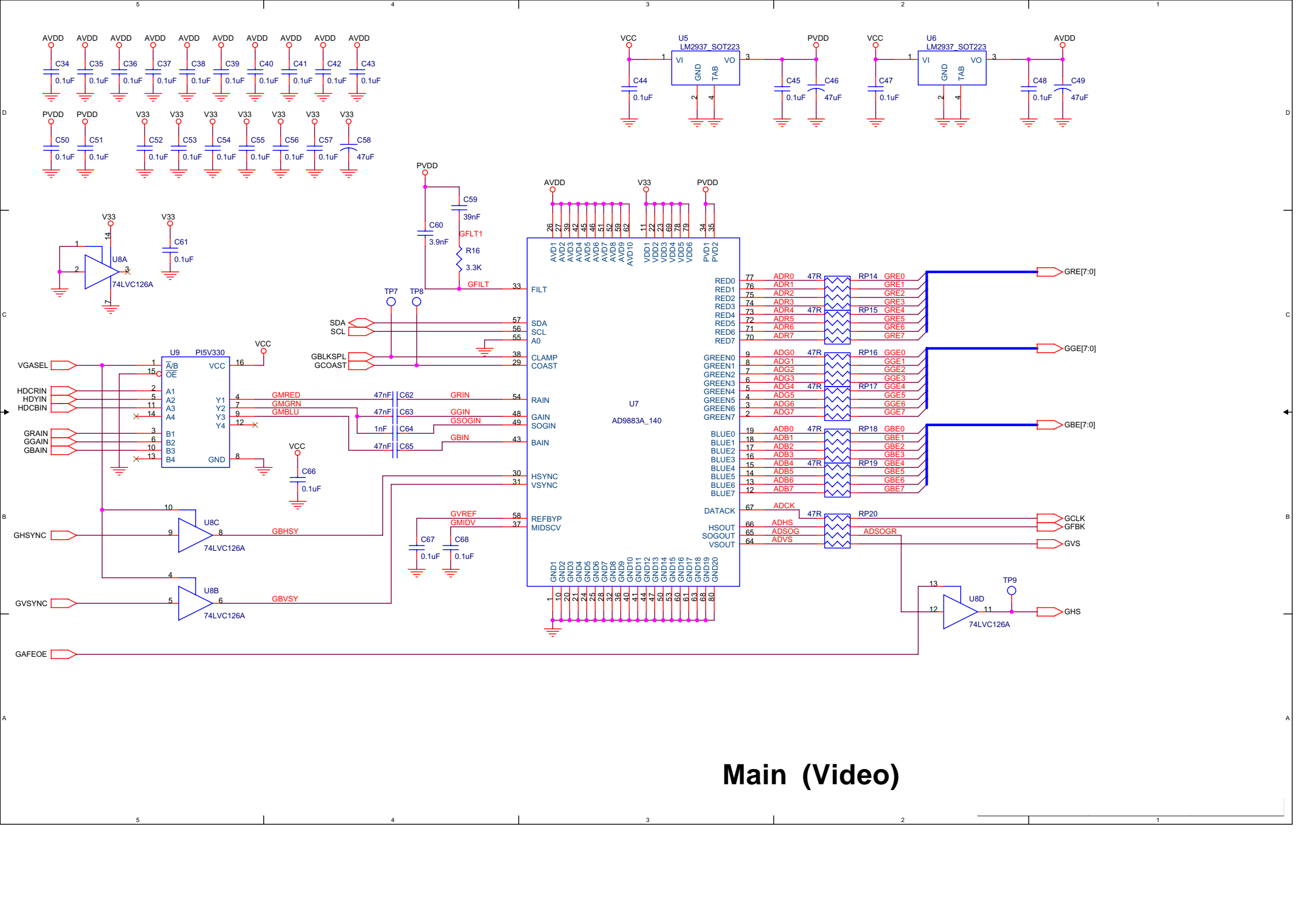

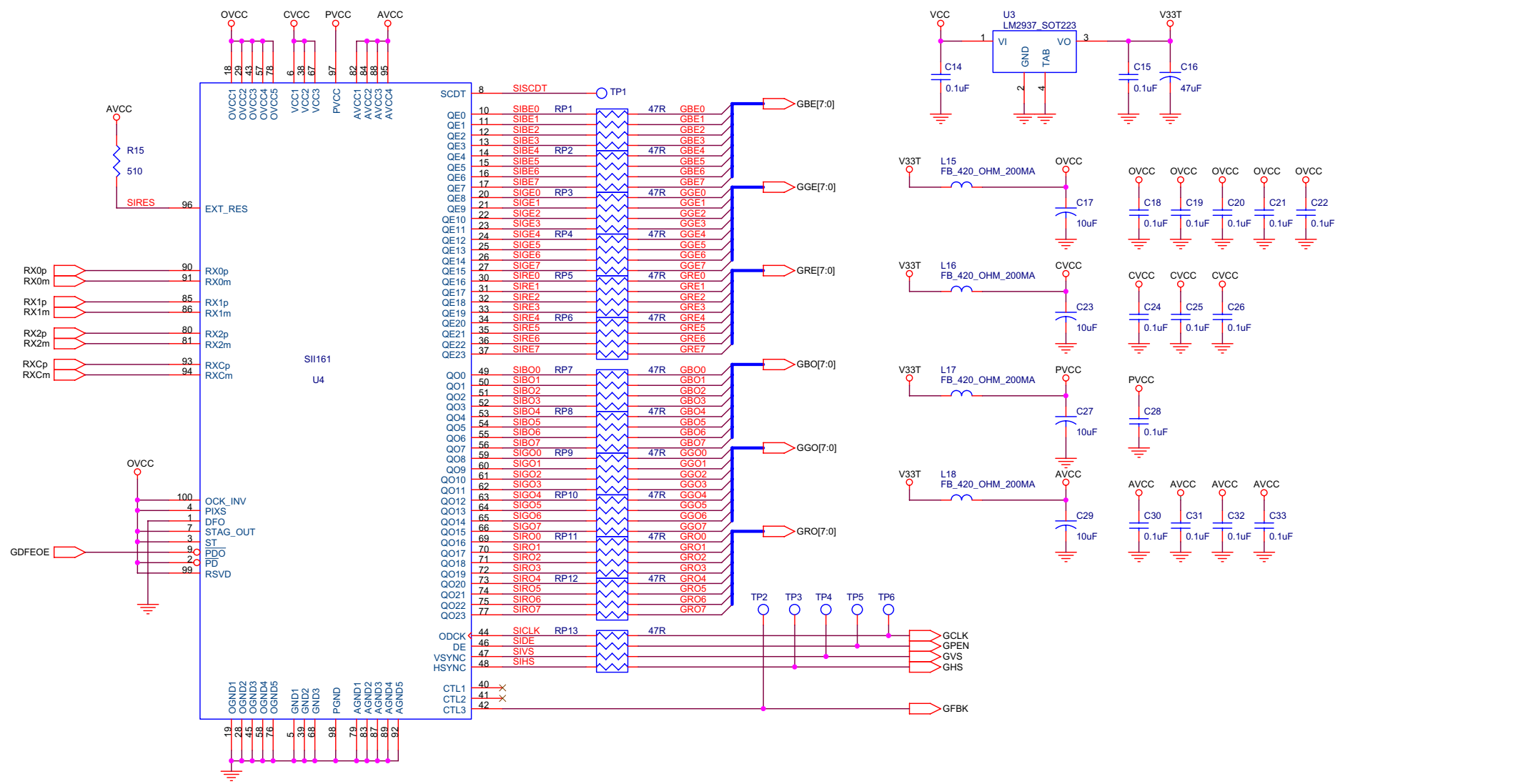

Main (Video)

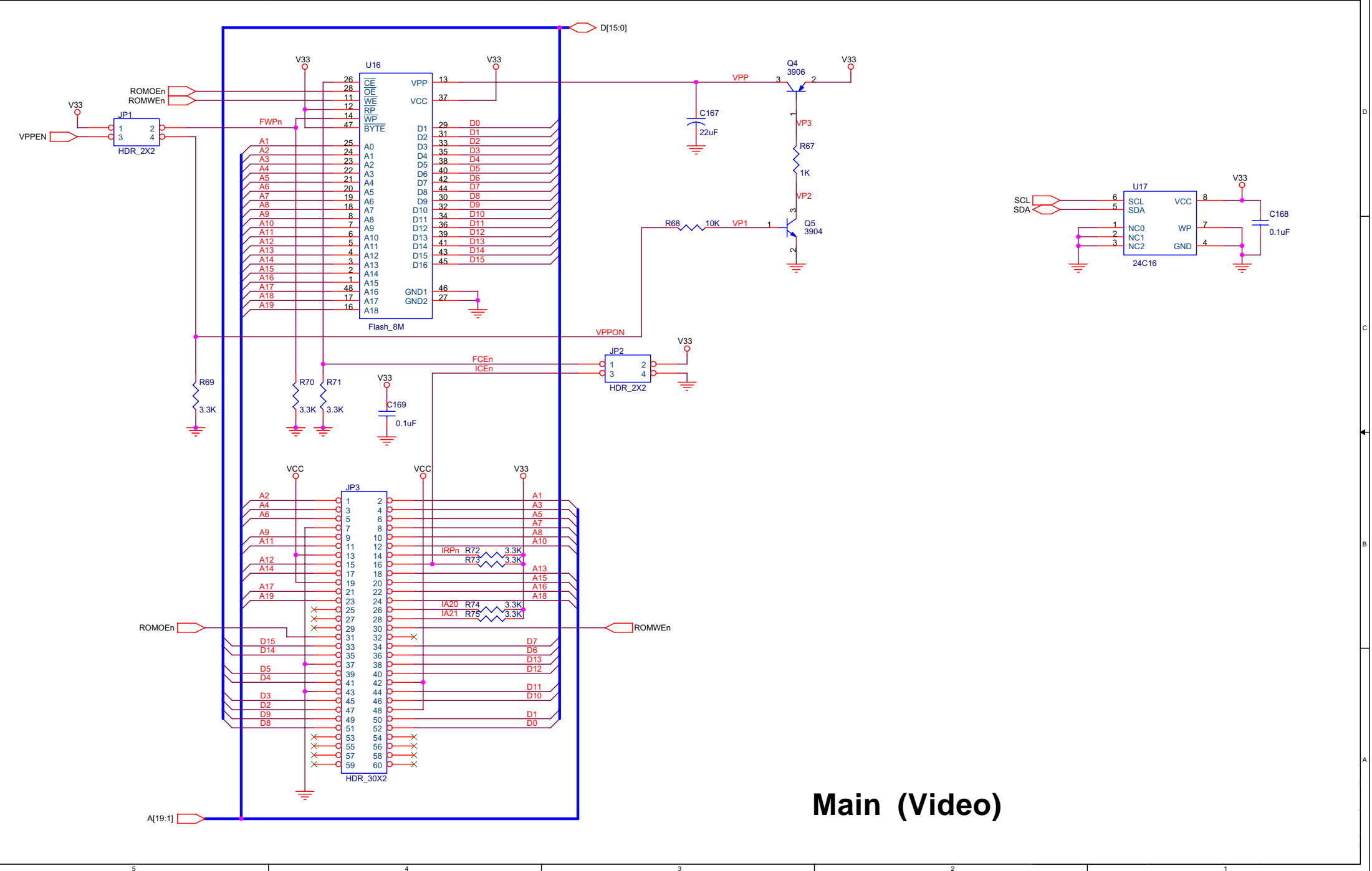

Main (Video)

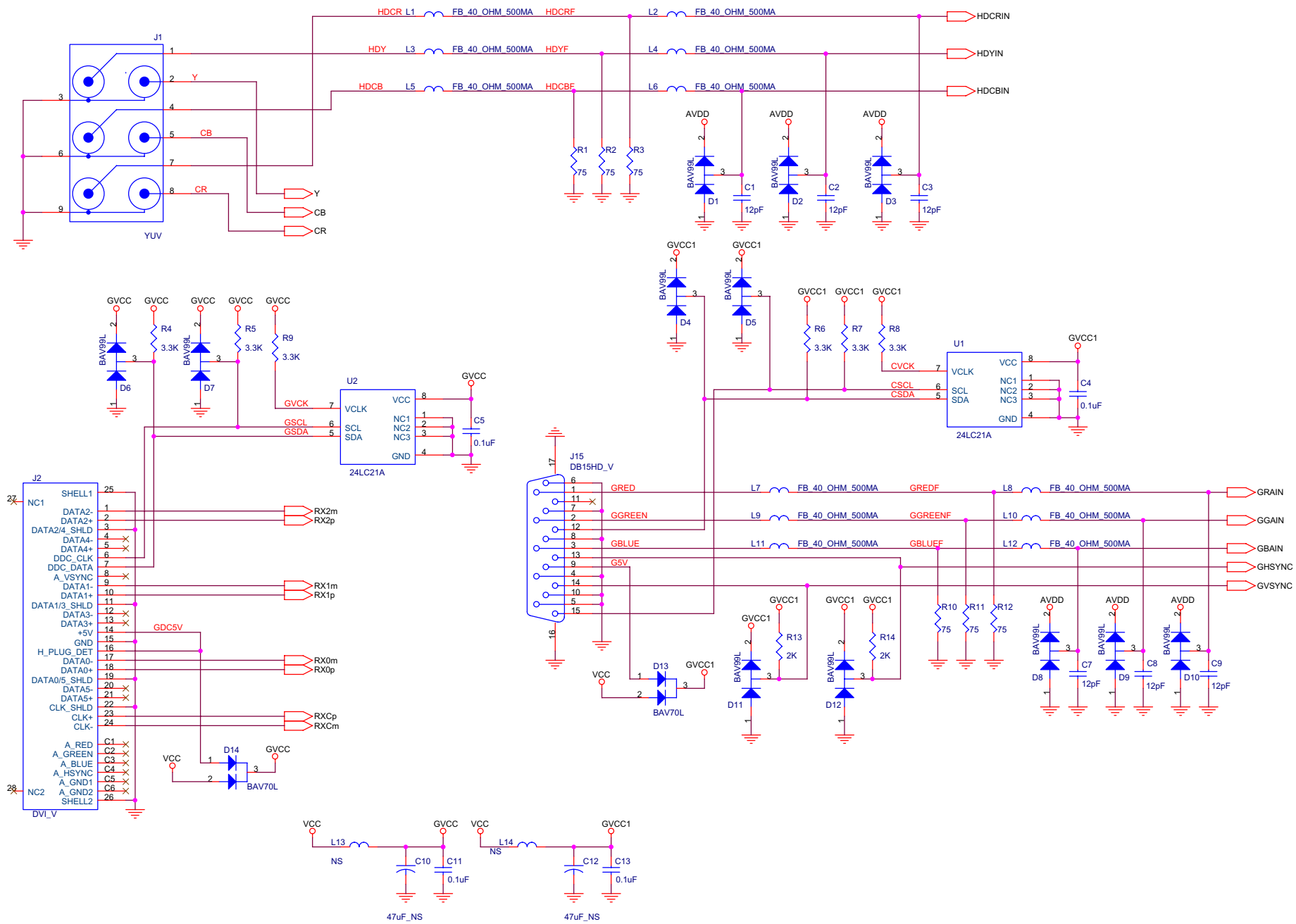

Main (Video)

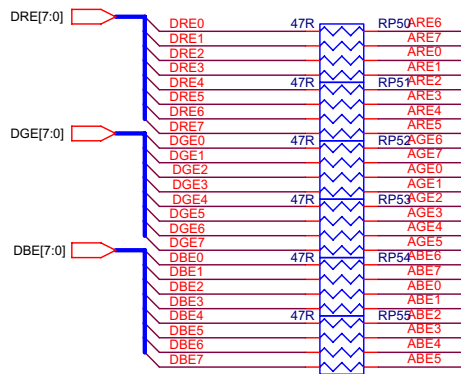
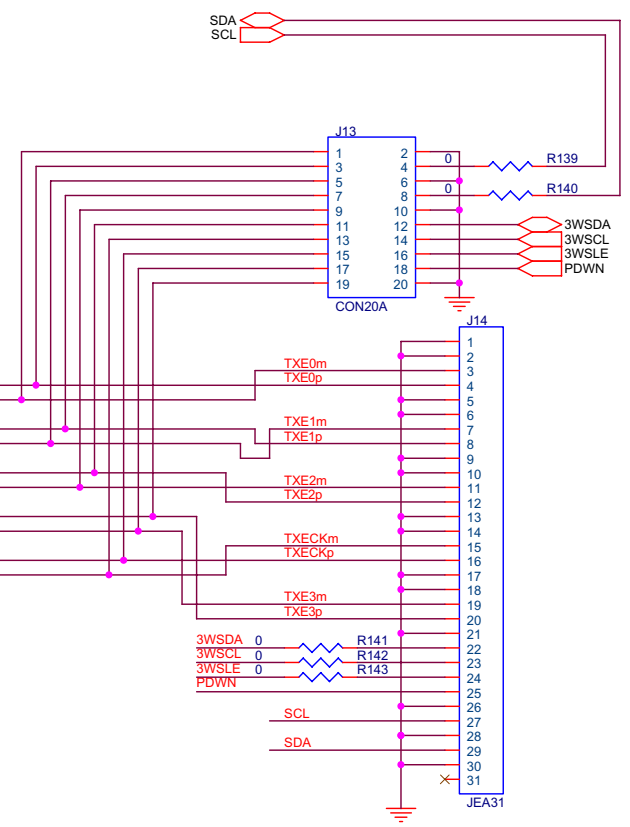
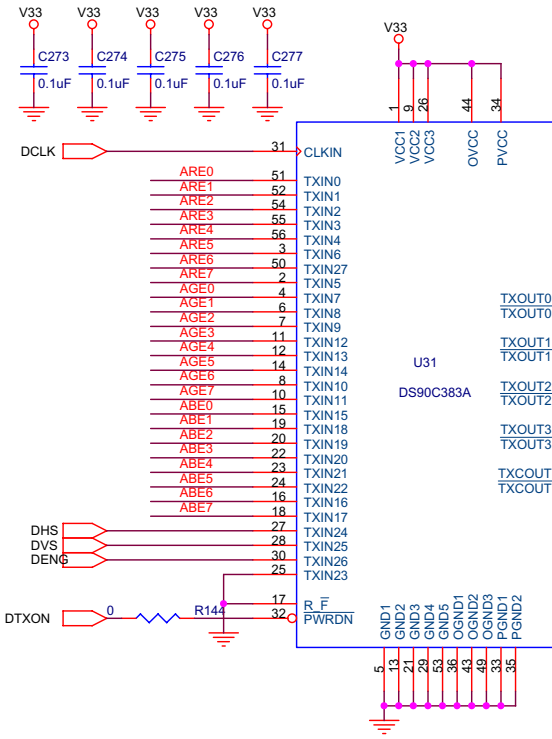
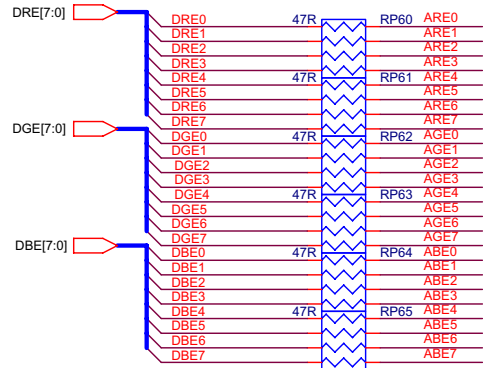

Main (Video)

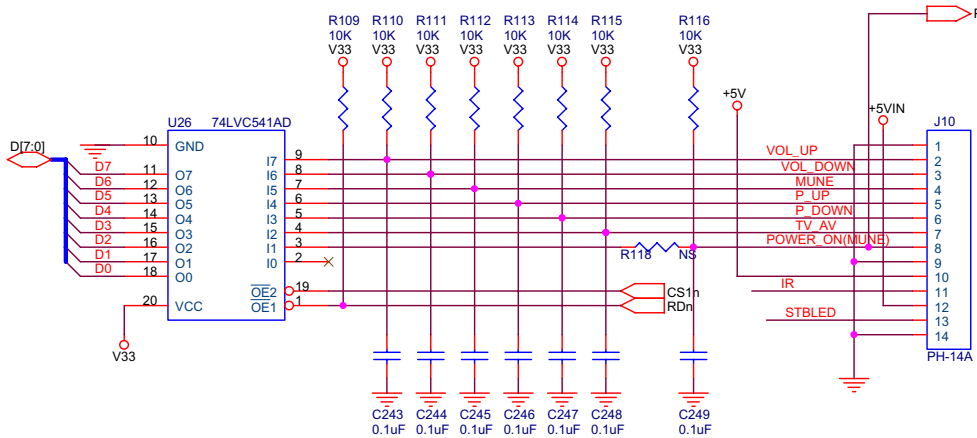
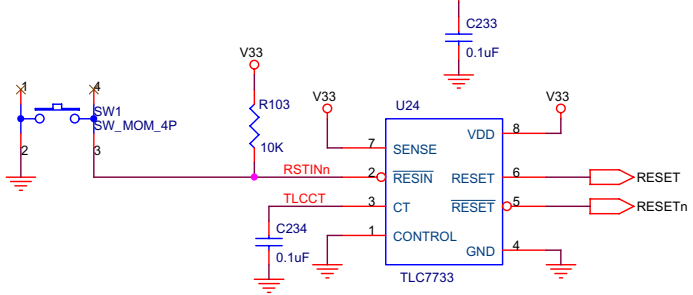
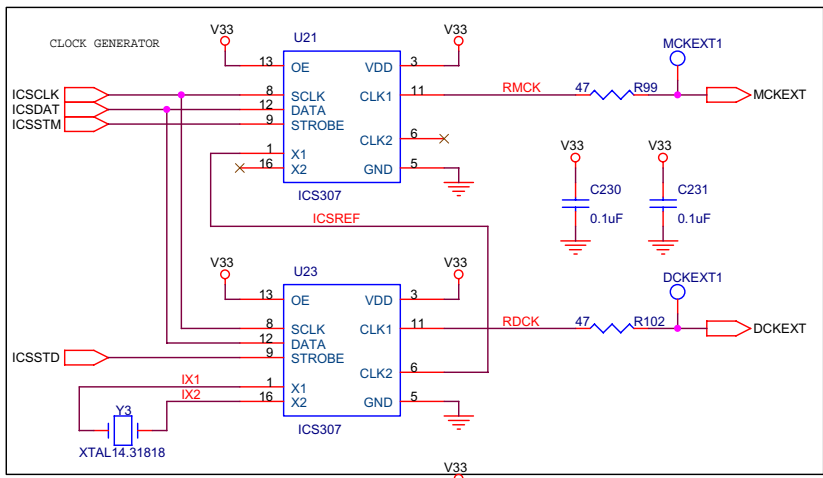

LED

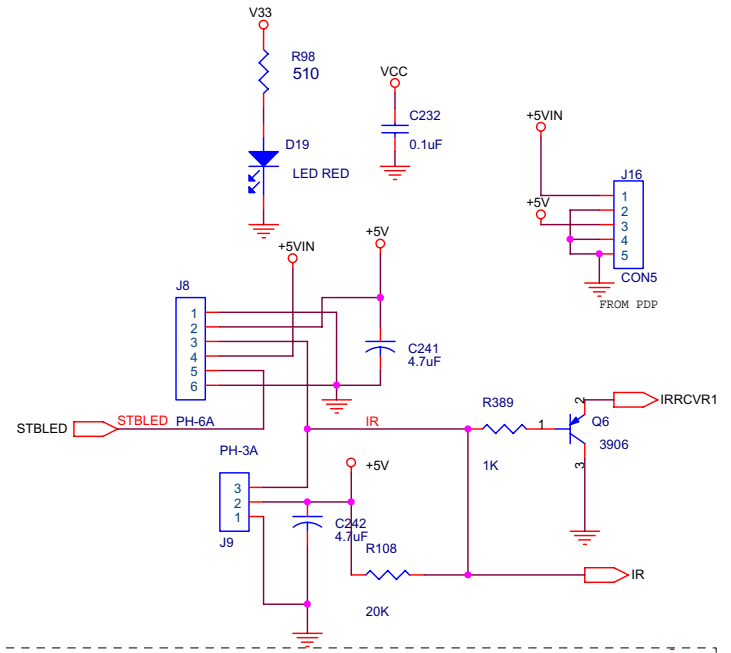
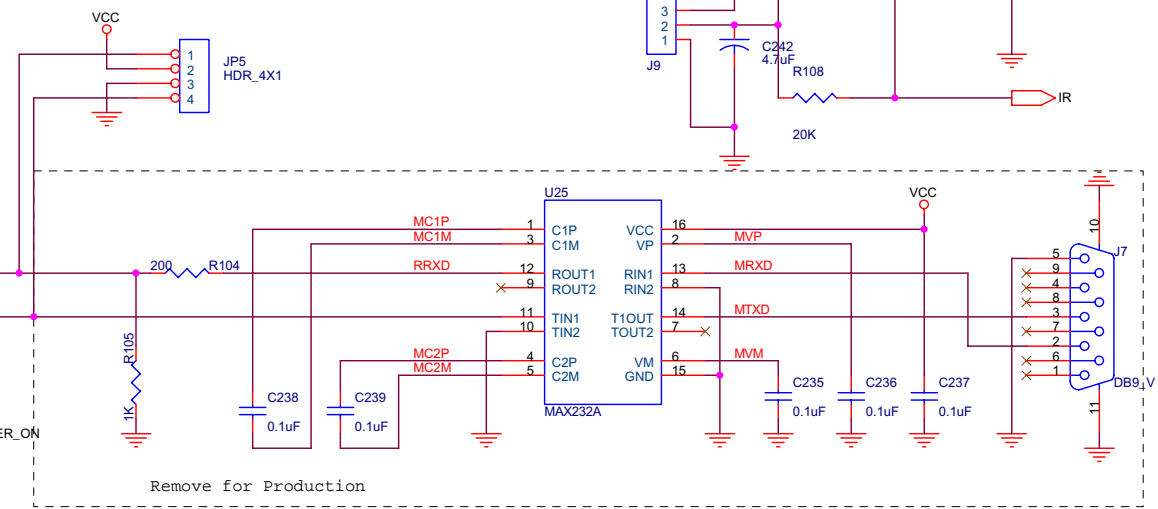
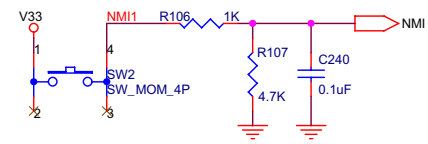

Main (Video)

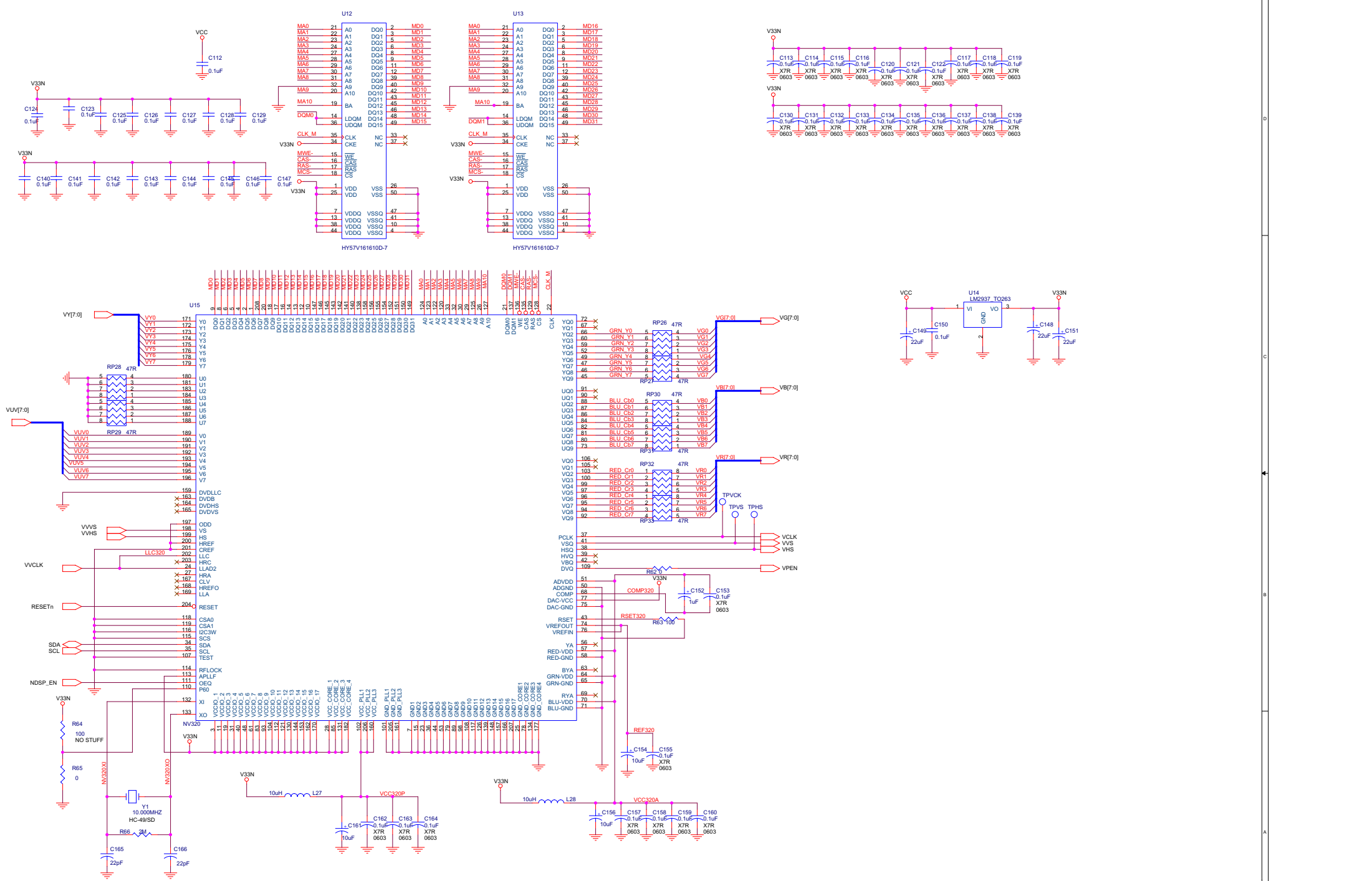

Main (Video)

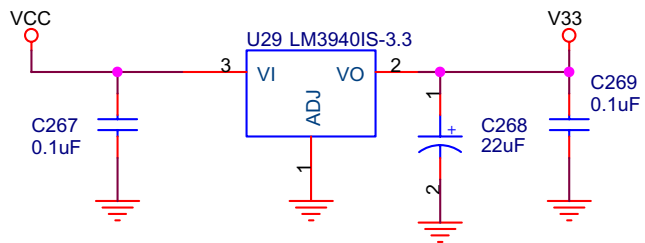
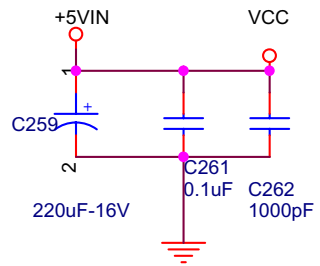
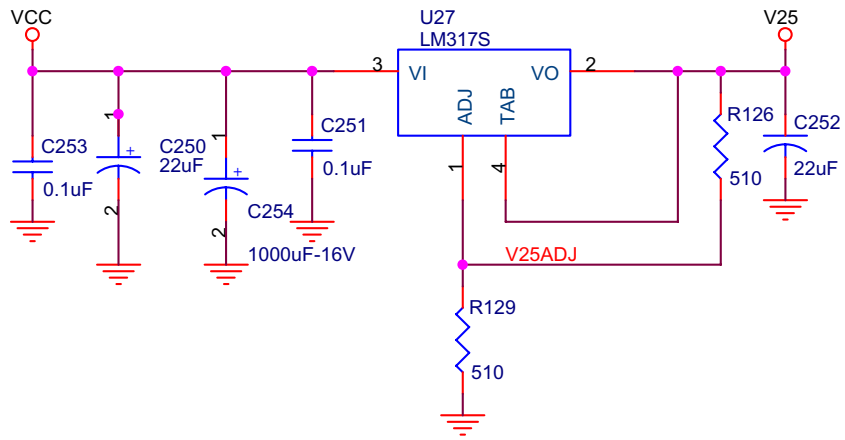

Main (Video)

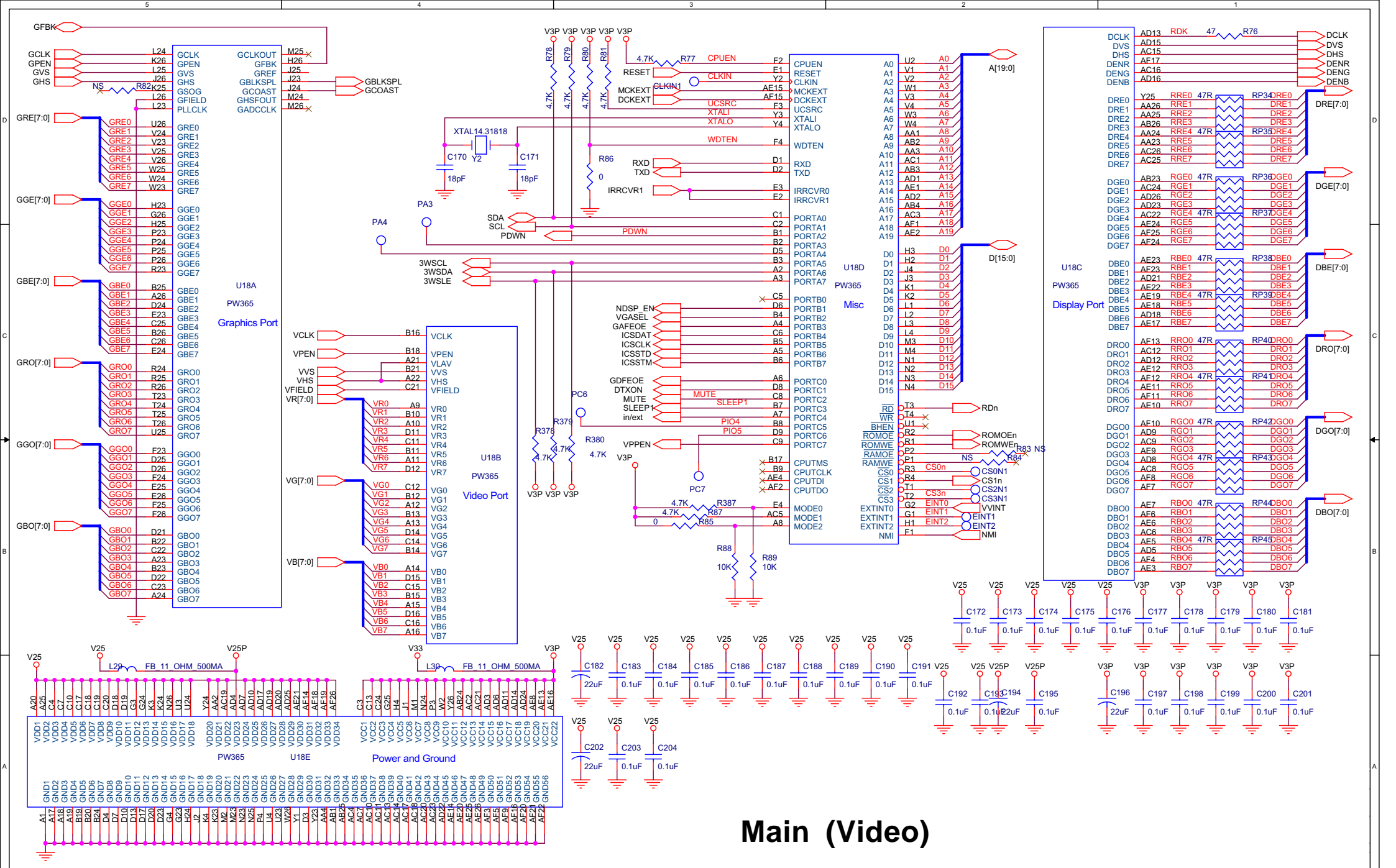

Main (Video)

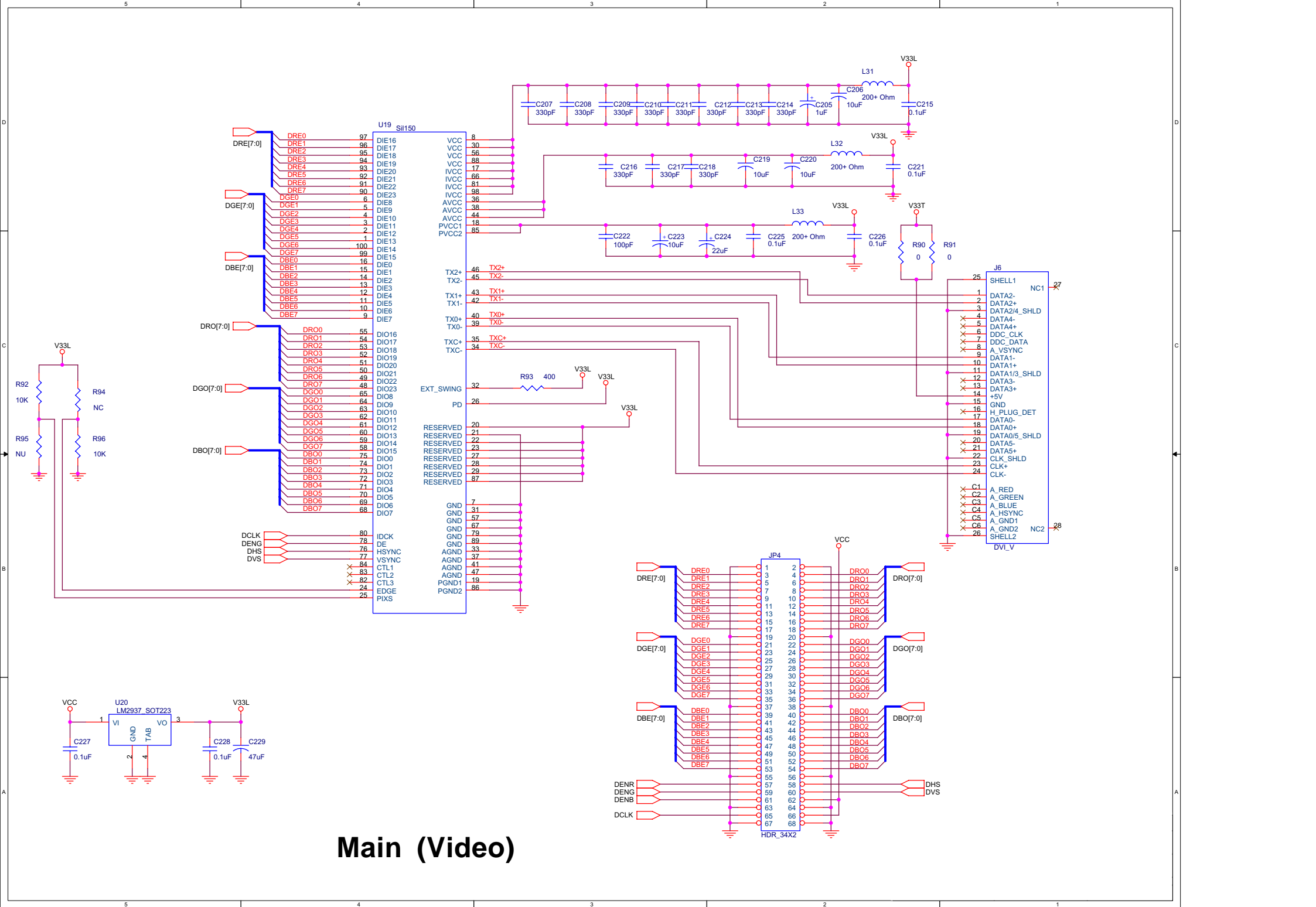

Main (Video)

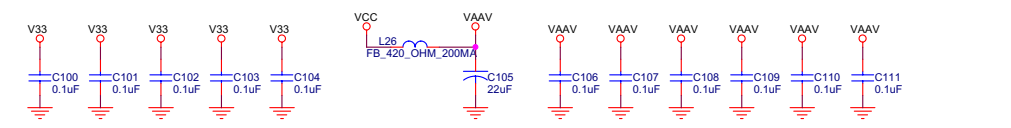
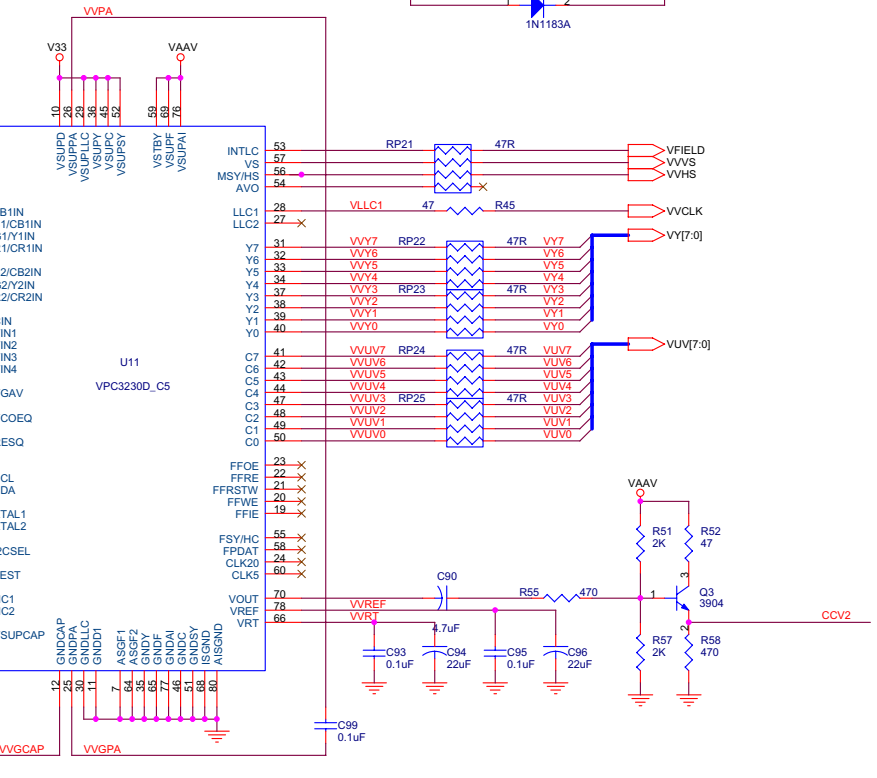
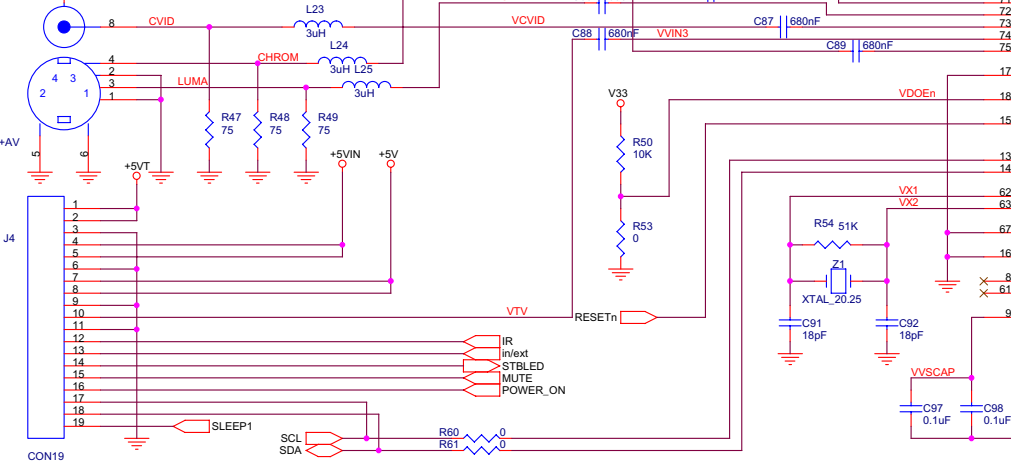
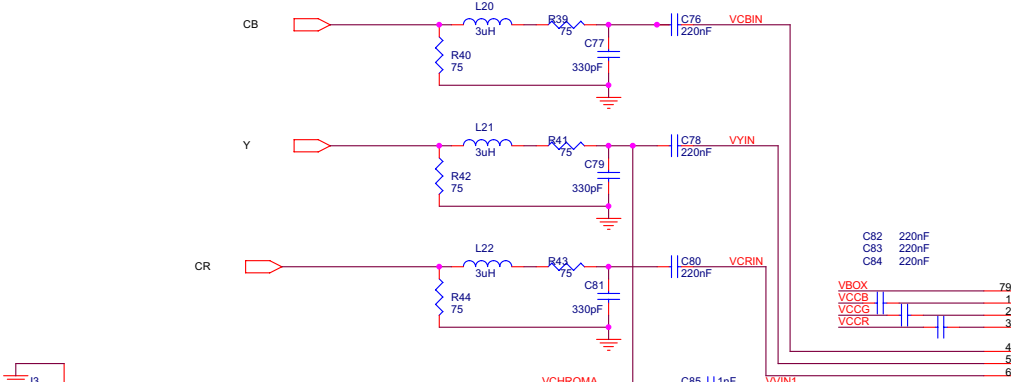
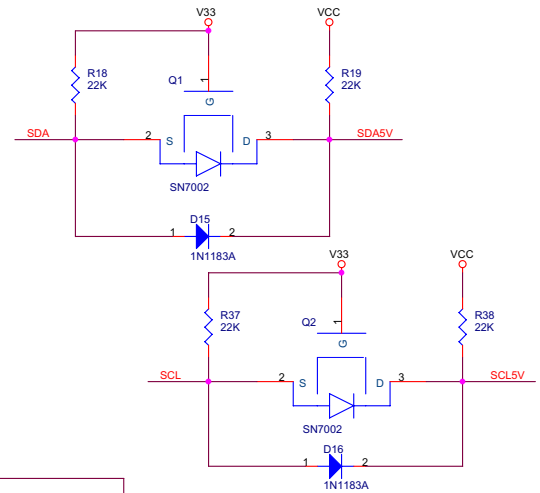
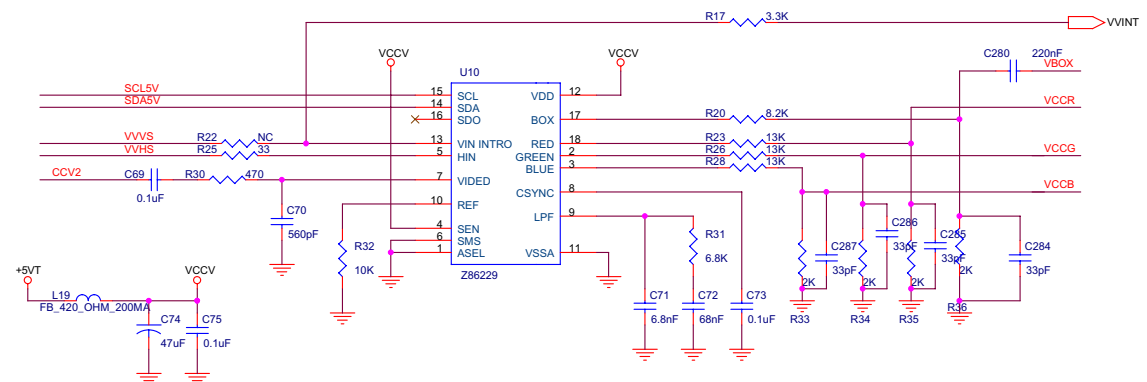

Main (Video)

02_INPUT

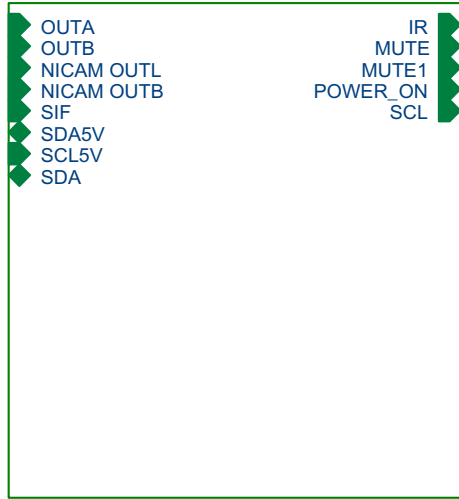

02_INPUT

03_NICAM

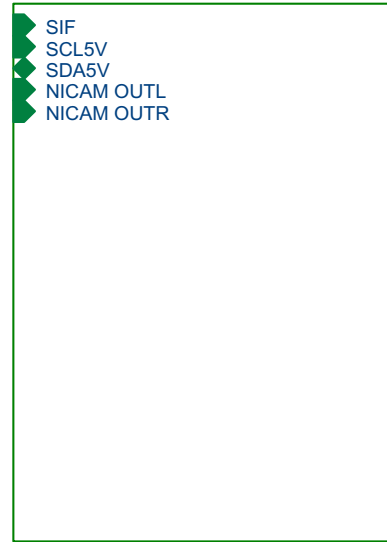

03_NICAM

04_MCU+AMP

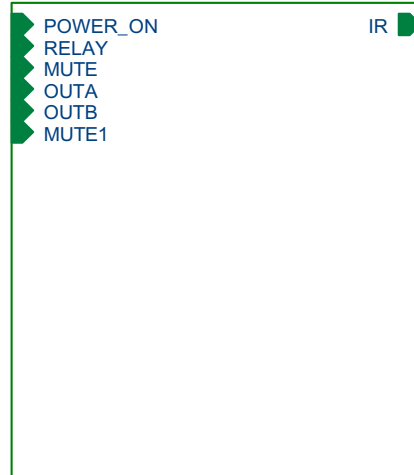

04_MCU+AMP

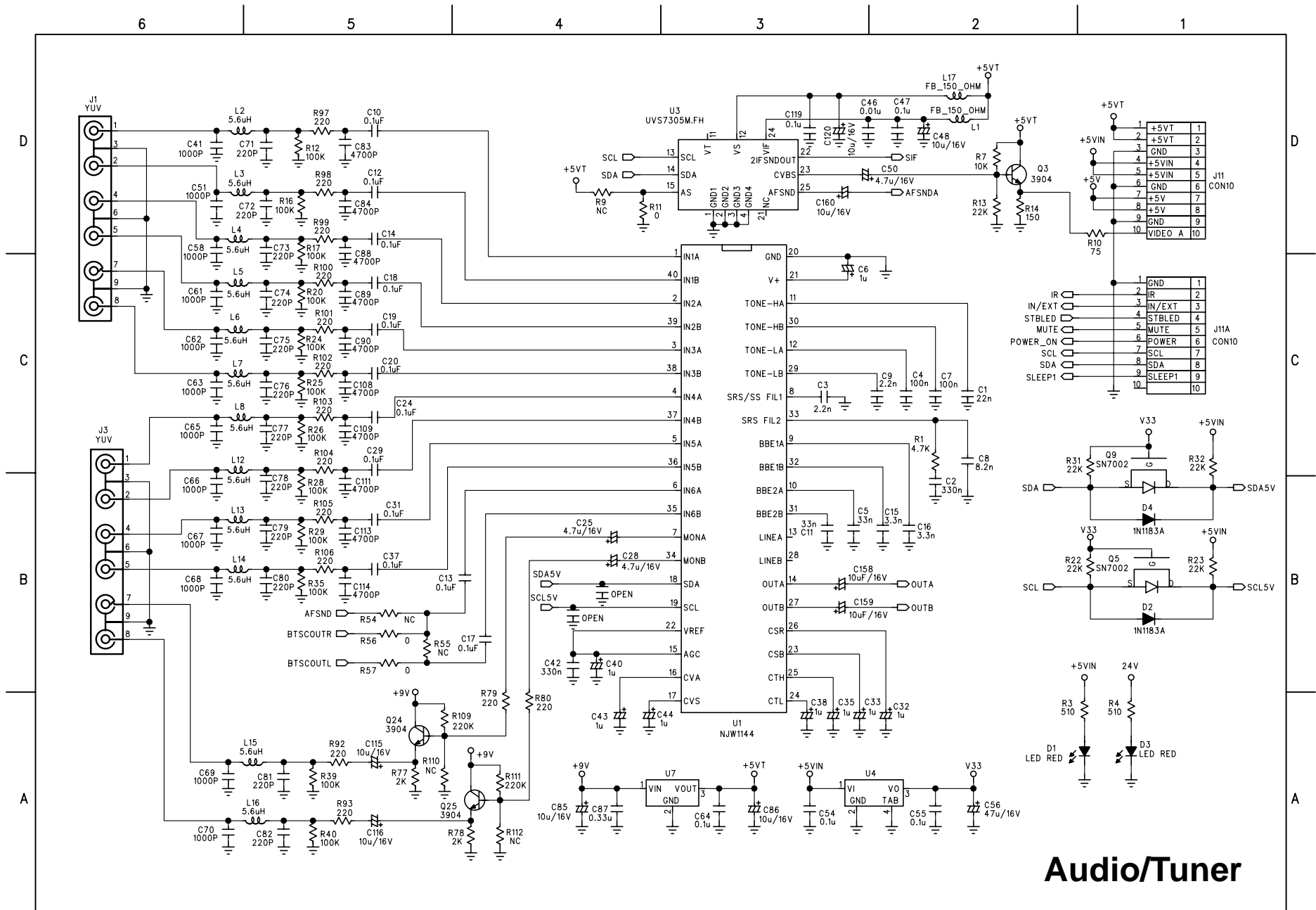

Audio/Tuner

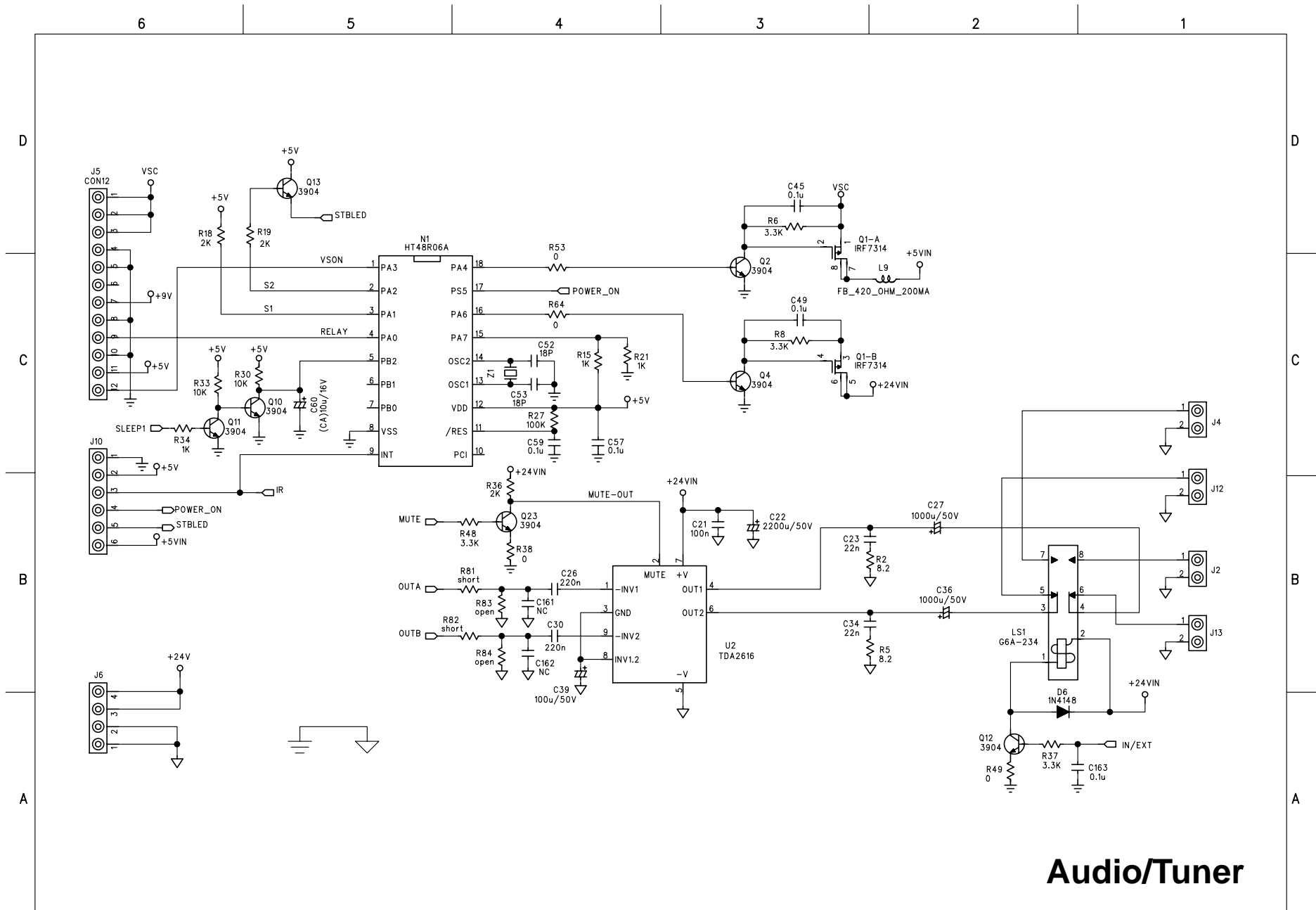

Audio/Tuner

6

5

4

3

2

1

D

C

B

A

D

C

B

A

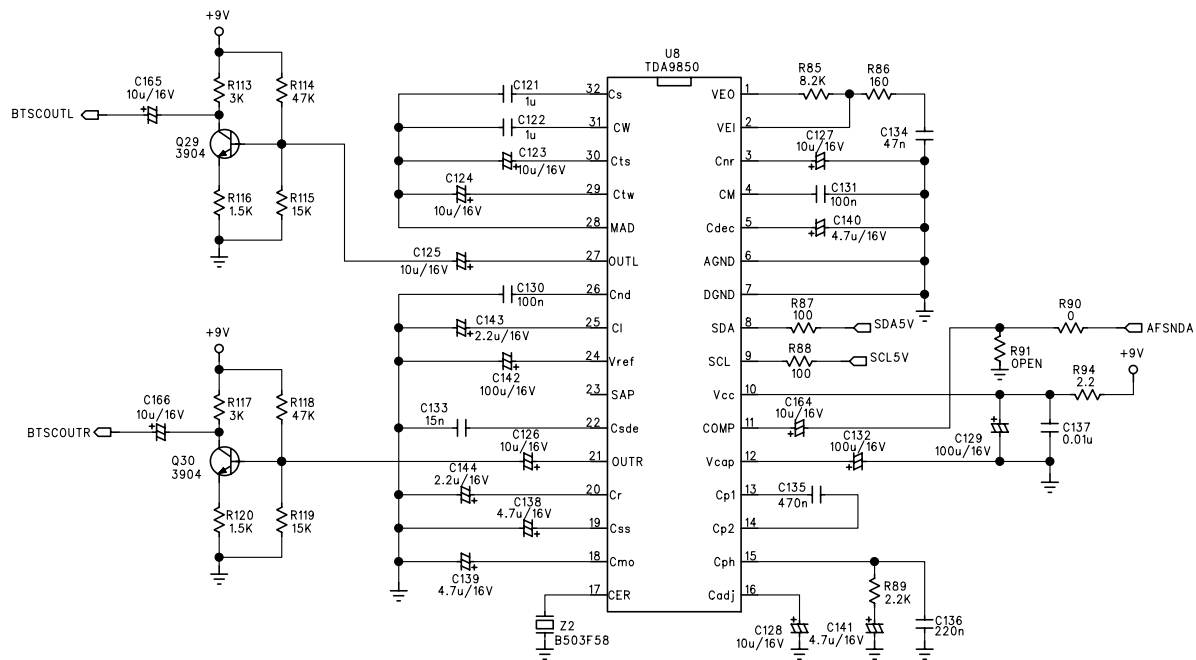

Audio/Tuner

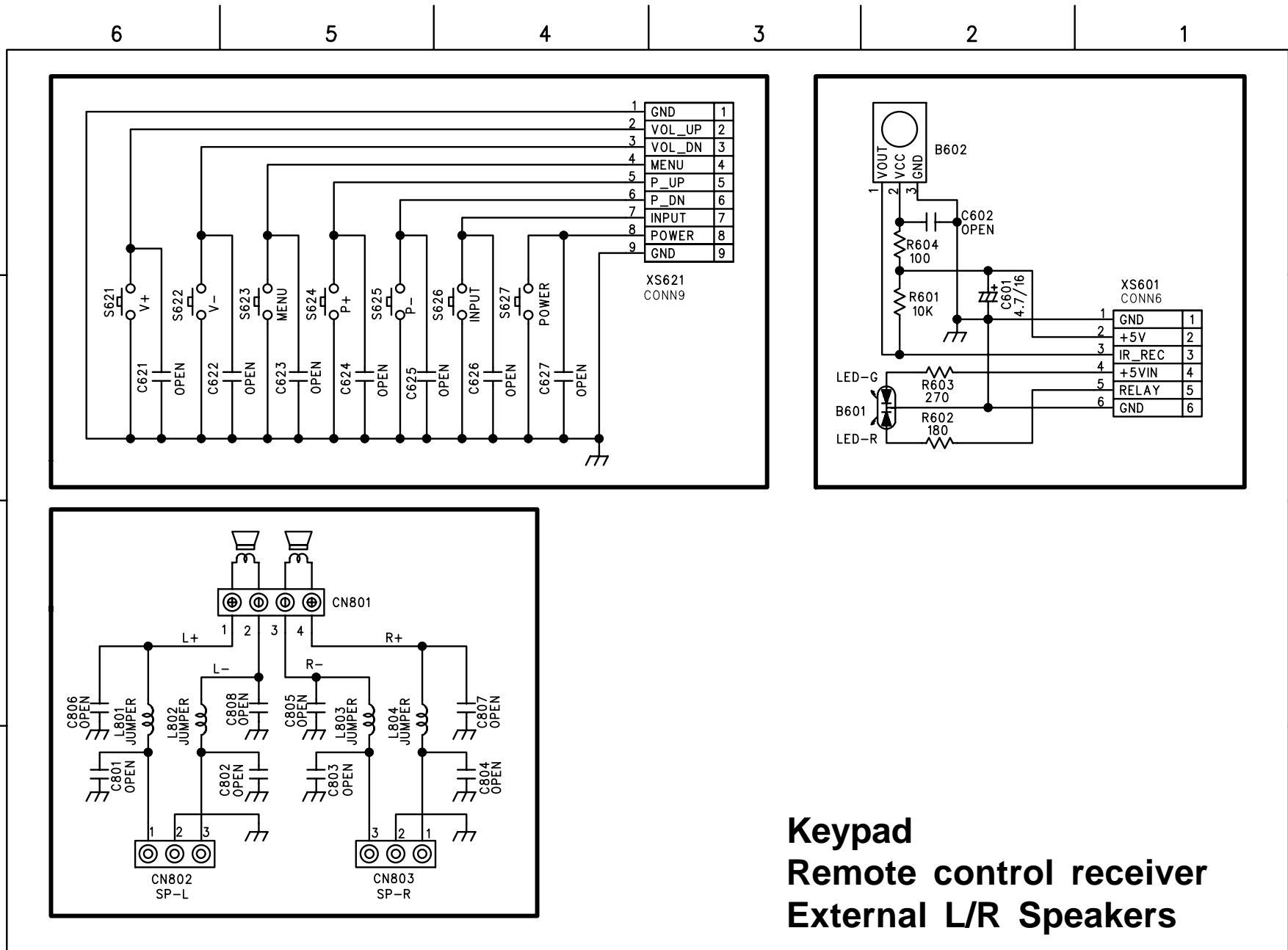

1	GND
2	VOL_UP
3	VOL_DN
4	MENU
5	P_UP
6	P_DN
7	INPUT
8	POWER
9	GND

1	GND
2	+5V
3	IR_REC
4	+5VIN
5	RELAY
6	GND

Keypad
Remote control receiver
External L/R Speakers

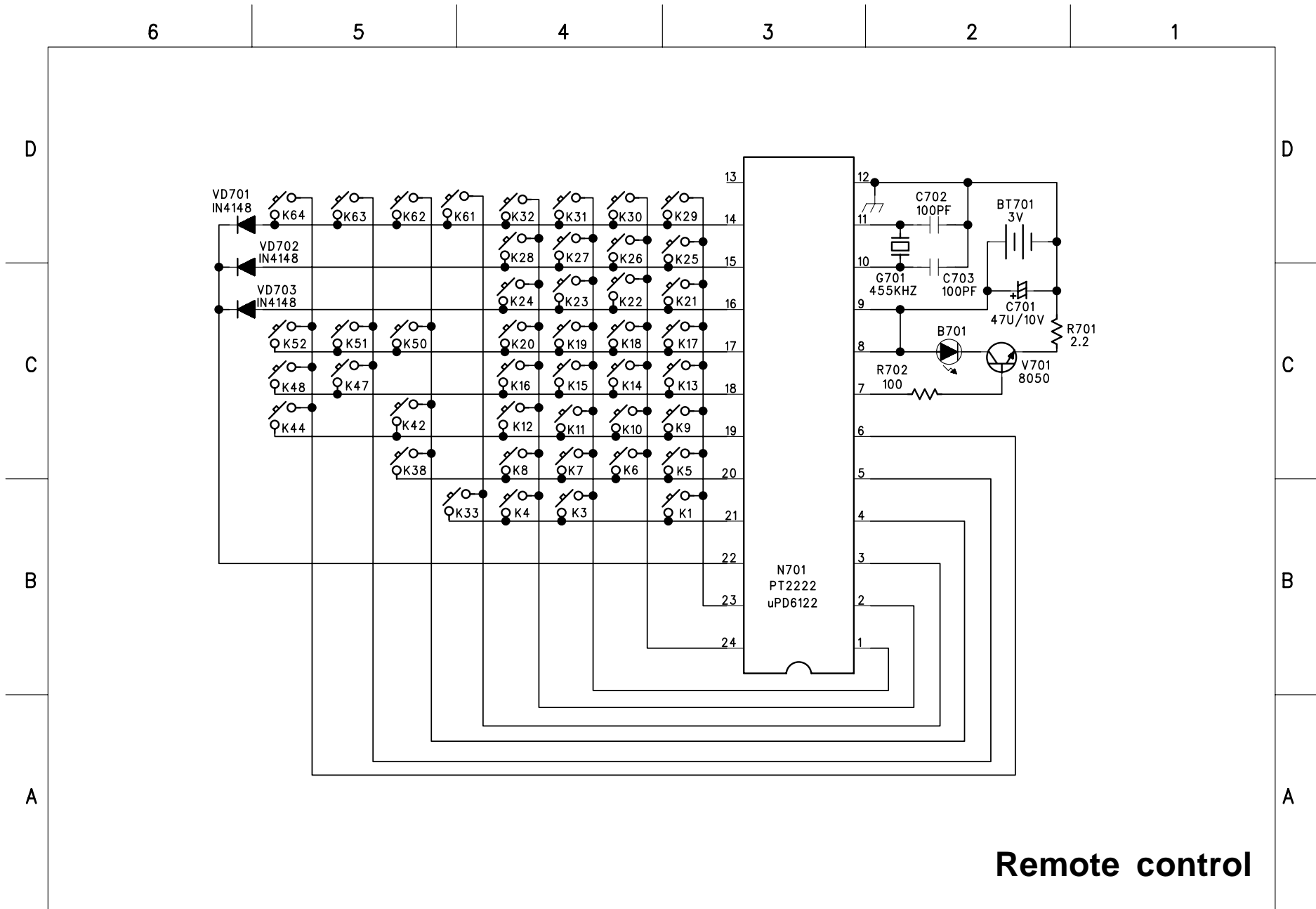

Remote control

Basic Operations & Circuit Description

MODULE

There are 1 pc. panel and 8 pc.s PCB including 2 pc.s Y/Z Sustainer board, 2 pc.s Y Drive board, 2 pc.s X (left and right) Extension PCB, 1 pc. Control (Signal Input) and 1 pc. Power board in the Module.

SET

There are 5 pc.s PCBs including 1 pc. Tuner/Audio board, 1 pc. Keypad board, 1 pc. Remote Control Receiver board, 1 pc. L/R Speakers and 1 pc. Main (Video) board in the SET.

Parts position

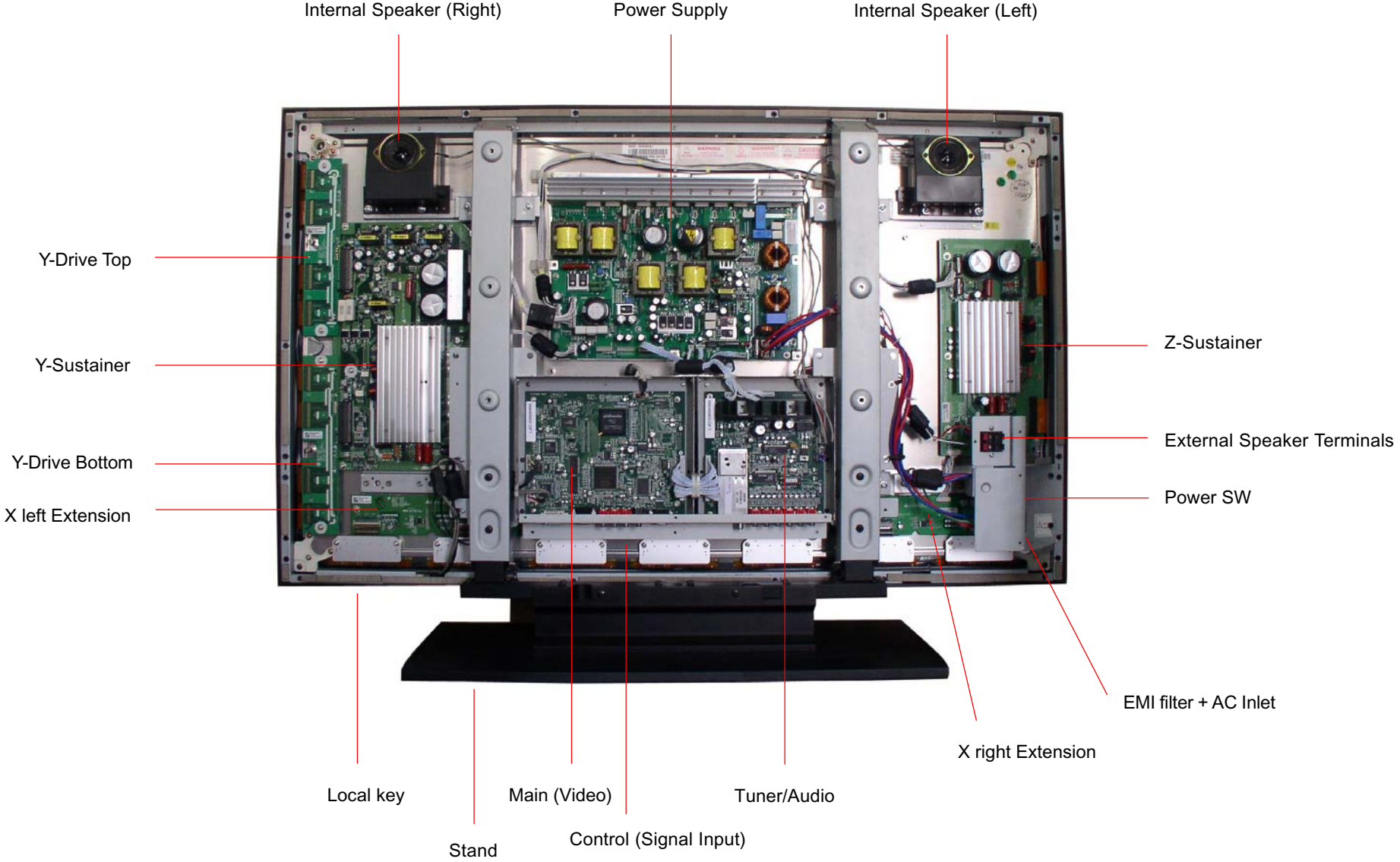

PCB function

1. Power:

(1). Input voltage: AC 110V~240V, 47Hz~63Hz.

Input range: AC 90V(Min)~265V(Max) auto regulation.

(2). To provide power for PCBs.

2. Main (Video InterFace) board: To converter TV signals, S signals, AV signals, Y Pb/Cb Pr/Cr signals, DVI signals and D-SUB signals to digital ones and to transmit to Control board.

3. Control board: Dealing with the digital signal for output to panel.

4. Y-Sustainer / Z-Sustainer board:

(1). Receiving the signals from Control and high voltage supply.

(2). Output scanning waveform for Module.

5. Y-Drive board: Receive signal from Y sustainer, output horizontal scanning waveform to the panel.

6. X (left and right) extension board: Output addressing signals.

7. Tuner/Audio Board: Amplifying the audio signal to the internal or external speakers of which selected.

To convert TV RF signal to video and audio signal to Main board.

PCB failure analysis

- 1. CONTROL: a. Abnormal noise on screen. b. No picture.**
- 2. MAIN (VIDEO): a. Lacking color, Bad color scale.
b. No voice.
c. No picture but with signals output, OSD and back light.
d. Abnormal noise on screen.**
- 3. POWER: No picture, no power output.**
- 4. Z - Sustainer: a. No picture.
b. Color not enough.
c. Flash on screen.**
- 5. Y - Sustainer: Darker picture with signals.**
- 6. Audio Bard: a. No voice. (Make sure status: Mute / Internal, External speaker)
b. Noise**
- 7. Y/Z - Sustainer: The component working temperature is about 55°C.
If the temperature rises abnormal, this may be a error point.**

Basic operation of Plasma Display

- 1. After turning on power switch, power board sends 5Vst-by Volt to Micro Processor IC waiting for ON signals from Key Switch or Remote Receiver.**
- 2. When the ON signal from Key Switch or Remote Receiver is detected, Micro Processor will send ON Control signals to Power. Then Power sends (5Vsc, 9Vsc, 24V and RLY ON, Vs ON) to PCBs working. This time VIF will send signals to display back light, OSD on the panel and start to search available signal sources. If the audio signals input, them will be amplified by Audio AMP and transmitted to Speakers.**
- 3. If some abnormal signals are detected (for example: over volts, over current, over temperature and under volts), the system will be shut down by Power off.**

Main IC Specifications

- **PW171 Image Processor**
- **AD9883A 110MSPS/140MSPS Analog Interface for Flat Panel Displays**
- **NV320 Video Enhancement Processor**
- **VCP 323XD comb Filter Video Processor**
- **Sil161B Panel Link Receiver**
- **Z86229 NTSC Line 21 CCD Decoder**
- **TDA9850 BTSC stereo/SAP decoder**
- **NJW1144 Audio Processor**

Product Specification: PW171 ImageProcessor

XGA/SXGA/UXGA Flat Panel Display Controller IC

to result in a personal injury or loss of life. Customers using or selling Pixelworks devices for use in such

Preliminary



General Description

PW171 is a highly integrated "system-on-a-chip" that interfaces analog, digital, and video inputs in virtually any format to a flat panel monitor or multimedia display. PW171 is pin-compatible with the PW364.

An embedded SDRAM frame buffer and memory controller perform frame rate conversion. Computer images from VGA to UXGA at almost any refresh rate can be resized to fit on a fixed-frequency target display device with any resolution up to UXGA with full 24-bit color.

PW171 includes advanced second-generation image scaling that provides completely programmable, horizontal and vertical image scaling.

PW171 also includes advanced second-generation sync decoding which provides full support for a wide variety of sync types. This includes interlaced, progressive, sync-on-green, and TMDS DE (Data Enable) only.

PW171 ImageProcessor supports NTSC or PAL video data with a 4:3 aspect ratio and 16:9 aspect ratio sources, such as DVD or HDTV. Nonlinear scaling and separate horizontal and vertical scalers allow these inputs to be resized optimally for the native resolution and aspect ratio of the display device.

PW171 uses an integrated PLL to synchronize the display interface timing to the input timing. This requires only a single external crystal to generate all necessary clocks for the system.

An integrated OSD controller provides bit-mapped based OSDs with 16 colors from a 64K color palette. The OSD controller supports transparent and translucent functions.

PW171 provides a Pulse Width Modulation (PWM) output for low cost backlight or audio control.

With reference source code and an on-chip microprocessor, manufacturers can develop feature-rich products with rapid time-to-market. Programmable features include the user interface, custom start-up screen, all automatic imaging features, and special screen effects.

PW171 incorporates new features while maintaining backward compatibility with the PW264 and PW364 ImageProcessors.

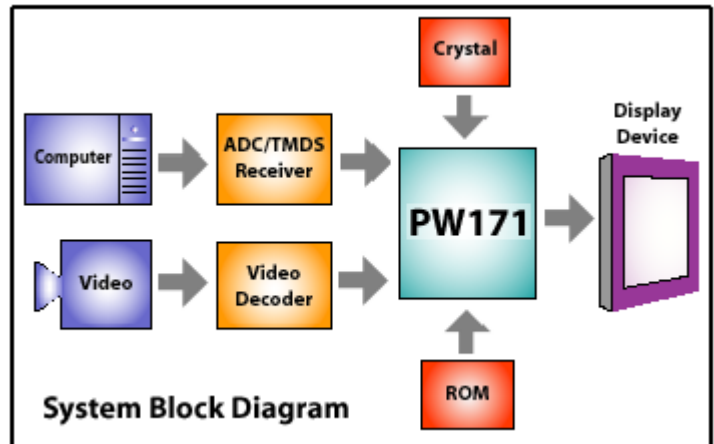

Features

- ❑ Second-generation Image Scaling
- ❑ Second-generation Automatic Image Optimization
- ❑ Color Space Converter for graphics inputs
- ❑ Video processing
- ❑ Picture-In-Picture (PIP)
- ❑ Frame rate conversion
- ❑ Color matrix for improved color temperature adjustment
- ❑ On-board PLLs to generate MCLK and DCLK
- ❑ On-screen display
- ❑ On-chip microprocessor
- ❑ JTAG debugging port
- ❑ 8-bit, 9-bit, or 10-bit display outputs
- ❑ 24-bit CPU Addressing
- ❑ Hardware 2-Wire serial bus support
- ❑ Hardware PWM output

Applications

- ❑ LCD Monitors
- ❑ Plasma Displays
- ❑ Multimedia Displays



110 MSPS/140 MSPS Analog Interface for Flat Panel Displays

AD9883A

FEATURES

- 140 MSPS Maximum Conversion Rate
- 300 MHz Analog Bandwidth
- 0.5 V to 1.0 V Analog Input Range
- 500 ps p-p PLL Clock Jitter at 110 MSPS
- 3.3 V Power Supply
- Full Sync Processing
- Sync Detect for "Hot Plugging"
- Midscale Clamping
- Power-Down Mode
- Low Power: 500 mW Typical
- 4:2:2 Output Format Mode

APPLICATIONS

- RGB Graphics Processing
- LCD Monitors and Projectors
- Plasma Display Panels
- Scan Converters
- Microdisplays
- Digital TV

FUNCTIONAL BLOCK DIAGRAM

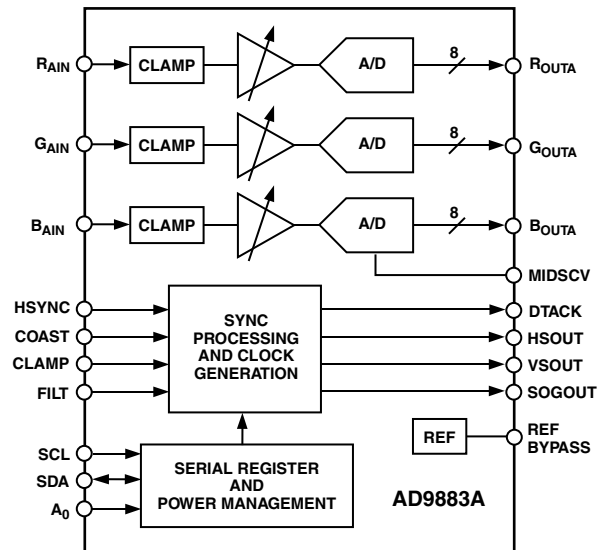

GENERAL DESCRIPTION

The AD9883A is a complete 8-bit, 140 MSPS monolithic analog interface optimized for capturing RGB graphics signals from personal computers and workstations. Its 140 MSPS encode rate capability and full power analog bandwidth of 300 MHz supports resolutions up to SXGA (1280 × 1024 at 75 Hz).

The AD9883A includes a 140 MHz triple ADC with internal 1.25 V reference, a PLL, and programmable gain, offset, and clamp control. The user provides only a 3.3 V power supply, analog input, and Hsync and COAST signals. Three-state CMOS outputs may be powered from 2.5 V to 3.3 V.

The AD9883A's on-chip PLL generates a pixel clock from the Hsync input. Pixel clock output frequencies range from 12 MHz to

140 MHz. PLL clock jitter is 500 ps p-p typical at 140 MSPS. When the COAST signal is presented, the PLL maintains its output frequency in the absence of Hsync. A sampling phase adjustment is provided. Data, Hsync, and clock output phase relationships are maintained. The AD9883A also offers full sync processing for composite sync and sync-on-green applications.

A clamp signal is generated internally or may be provided by the user through the CLAMP input pin. This interface is fully programmable via a 2-wire serial interface.

Fabricated in an advanced CMOS process, the AD9883A is provided in a space-saving 80-lead LQFP surface-mount plastic package and is specified over the 0°C to 70°C temperature range.

REV. A

Information furnished by Analog Devices is believed to be accurate and reliable. However, no responsibility is assumed by Analog Devices for its use, nor for any infringements of patents or other rights of third parties that may result from its use. No license is granted by implication or otherwise under any patent or patent rights of Analog Devices.

One Technology Way, P.O. Box 9106, Norwood, MA 02062-9106, U.S.A.
Tel:
Fax:

NV320 Video Enhancement Processor

1.0 Introduction

The NV320 is a single-chip, programmable video display processor providing advanced features for progressive scan, high frame-rate TV. The NV320 improves upon the functionality of the NV320P by handling non-standard video input signals. Other feature enhancements include DCTI, Black Level Stretch, and Saturation Control.

The NV320 offers the following features.

1.1 Highly Integrated Video Processor

- Three, on-chip, 10-bit Digital-to-Analog Converters (DACs)
- Built-in memory controller supporting SDRAM or SGRAM
- 0.35 μ CMOS process
- 3.3V power supply with 5V tolerant I/Os
- Standard 208-pin PQFP

1.2 Video Input

- Multiple video input modes
 - Data acquisition mode
 - Line-locked mode
 - DVD mode
- Multiple video input data formats
 - Digital 16-bit YUV (4:2:2) or 12-bit YUV (4:1:1)
 - Digital 8-bit YUV (ITU-R 656)
 - Digital 24-bit YUV (4:4:4)

1.3 Noise Reduction

- Motion adaptive noise reduction filter

1.4 Color Processing

- Built-in color space conversion
- Selectable output color space: YUV or RGB

1.5 Video Processing

- Advanced, non-linear video processing
- Motion compensated deinterlacing
- Programmable peaking
- Non-linear interpolation
- Background coloring

- Anti-flickering circuitry
- NTSC/PAL to SDTV 480p format conversion
- Frame rate up-conversion (50Hz up to 75Hz for PAL, 60Hz up to 90Hz for NTSC)
- DCTI (Digital Color Transient Improvement)
- Black Level Stretch
- Saturation Control

1.6 Host Interface

- I²C interface
- No programming needed for default mode application

1.7 General Description and Applications

The NV320 is a single chip digital video processor for progressive and digital TV applications. It provides high quality video processing including video noise reduction, motion compensation, sharpness enhancement, and resolution enhancement. It also provides frame rate conversion and progressive scan conversion with deinterlacing.

The NV320 is a CMOS mixed signal circuit highly integrated with three, 10-bit digital-to-analog converters controlled by the I²C interface. The NV320 accepts 16-bit YUV (4:2:2), 12-bit YUV (4:1:1), and 8-bit YUV (ITU-R 656) simultaneously, or it accepts 24-bit YUV (4:4:4) input from a front-end digital video color decoder or from an analog-to-digital converter. Additionally, NV320 supports multiple video input modes: acquisition mode, line-locked mode, and DVD mode.

The NV320 has an on-chip detection logic block that corrects non-standard input signals before processing.

Applications for the NV320 chip are listed here.

- Progressive scan televisions
- Digital televisions (the chip is DTV/HDTV ready)

- Internet televisions
- Home theater and multimedia televisions
- Video conferencing

2.0 Ordering Information

Part Number	NV320
Package	PQFP 208
Description	Plastic quad flat package, 208 leads
Version	1.0

3.0 Block Diagram of NV320

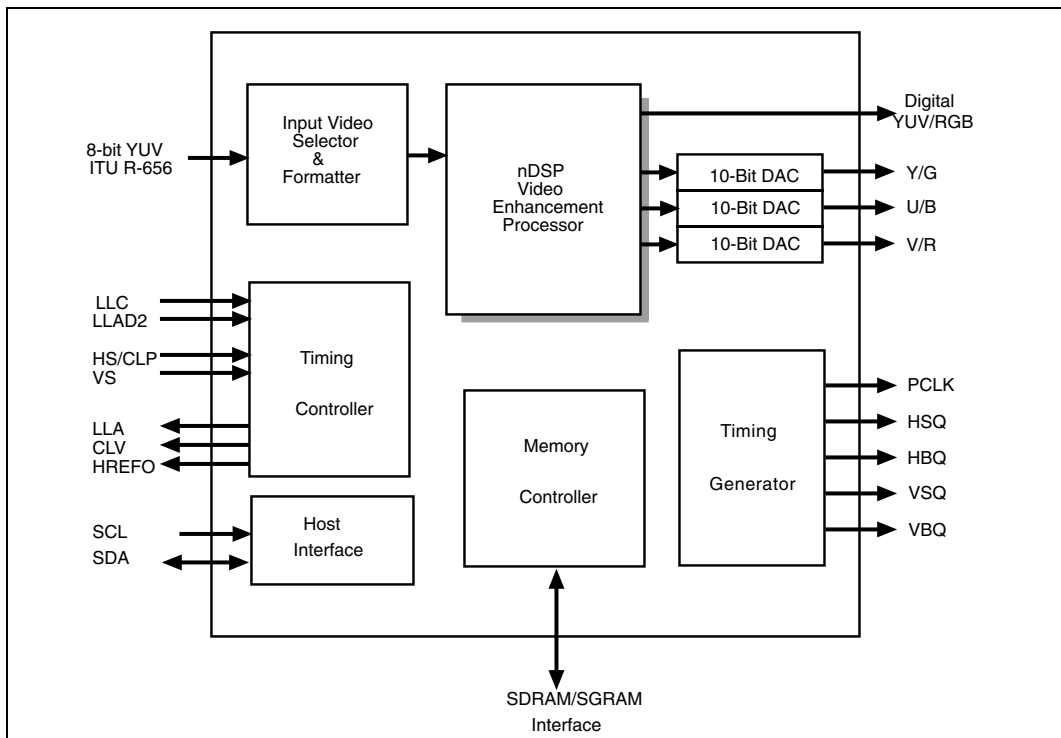

Figure 1. Block Diagram of NV320

VPC 323xD Comb Filter Video Processor

1. Introduction

The VPC 323xD is a high-quality, single-chip video front-end, which is targeted for 4:3 and 16:9. 50/60 Hz and 100/120 Hz TV sets. It can be combined with other members of the DIGIT3000 IC family (such as DDP 331x) and/or it can be used with 3rd-party products.

The main features of the VPC 323xD are

- High-performance adaptive 4H comb filter Y/C separator with adjustable vertical peaking.
- Multi-standard color decoder PAL/NTSC/SECAM including all substandards.
- Four CVBS, one S-VHS input, one CVBS output.
- Two RGB/YCrCb component inputs, one Fast Blank (FB) input.
- Integrated high-quality A/D converters and associated clamp and AGC circuits.
- Multi-standard sync processing.
- Linear horizontal scaling (0.25.....4), as well as nonlinear horizontal scaling 'Panoramavision'.
- PAL+ preprocessing.
- Line-locked clock, data and sync, or 656-output interface.
- Peaking, contrast, brightness, color saturation and tint for RGB/YCrCb and CVBS/S-VHS.
- High-quality soft mixer controlled by Fast Blank.
- PIP processing for four picture sizes (1/4, 1/9, 1/16, or 1/36 of normal size) with 8-bit resolution.
- Control interface for external field memory.
- I²C-bus interface.
- One 20.25-MHz crystal, few external components.
- 80-pin PQFP package.

General Description

The SiI 161B receiver uses PanelLink Digital technology to support high-resolution displays up to UXGA (25-165MHz). This receiver supports up to true color panels (24 bits per pixel, 16M colors) with both one and two pixels per clock.

All PanelLink products are designed on a scaleable CMOS architecture, ensuring support for future performance enhancements while maintaining the same logical interface. System designers can be assured that the interface will be stable through a number of technology and performance generations.

PanelLink Digital technology simplifies PC and display interface design by resolving many of the system level issues associated with high-speed mixed signal design, providing the system designer with a digital interface solution that is quicker to market and lower in cost.

Features

- Low Power Operation: 280mA max. current consumption at 3.3V core operation
 - Time staggered data output for reduced ground bounce and lower EMI
 - Sync Detect feature for Plug & Display
 - Cable Distance Support: over 5m with twisted-pair, fiber-optics ready
 - ESD tolerant to 5kV (HBM on all pins)
 - Compliant with DVI 1.0 (DVI is backwards compatible with VESA® P&D™, FPDI-2™ and DFP)
 - HSYNC de-jitter circuitry enables stable operation even when HSYNC contains jitter
 - Low power standby mode
 - Automatic entry into standby mode with clock detect circuitry
 - Standard and Pb-free packages (see page 25).
-

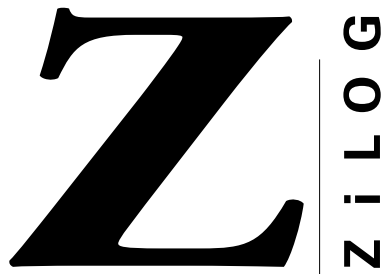

Totally Logical

Z86229

NTSC LINE 21 CCD DECODER

FEATURES

Devices	Speed (MHz)	Pin Count/ Package Types	Standard Temp. Range	Automatic Data Extraction		
				On-Screen Display & Closed Captioning	Program Rating	Time of Day
Z86229	12	18-Pin DIP, SOIC	0°C to +70°C	Yes	Yes	Yes

- Complete Stand-Alone Line 21 Decoder for Closed-Captioned and Extended Data Services (XDS)
- Preprogrammed to Provide Full Compliance with EIA-608 Specifications for Extended Data Services
- Automatic Extraction and Serial Output of Special XDS Packets (Time of Day, Local Time Zone, and Program Blocking)
- Programmable XDS Filter for a Specific XDS Packet
- Cost-Effective Solution for NTSC Violence Blocking inside Picture-in-Picture (PiP) Windows
- Minimal Communications and Control Overhead Provide Simple Implementation of Violence Blocking, Closed Captioning, and Auto Clock Set Features
- Programmable, On-Screen Display (OSD) for Creating Full Screen OSD or Captions inside a Picture-in-Picture (PiP) Window
- User-Programmable Horizontal Display Position for easy OSD Centering and Adjustment
- I²C Serial Data and Control Communication
- Supports 2 Selectable I²C Addresses

GENERAL DESCRIPTION

Capable of processing Vertical Blanking Interval (VBI) data from both fields of the video frame in data, the Z86229 Line 21 Decoder offers a feature-rich solution for any television or set-top application. The robust nature of the Z86229 helps the device conform to the transmission format defined in the Television Decoder Circuits Act of 1990, and in accordance with the Electronics Industry Association specification 608 (EIA-608).

The Line 21 data stream can consist of data from several data channels multiplexed together. Field 1 consists of four data channels: two Captions and two Texts. Field 2 consists of five additional data channels: two Captions, two Texts, and Extended Data Services (XDS). The XDS data structure is

defined in EIA-608. The Z86229 can recover and display data transmitted on any of these nine data channels.

The Z86229 can recover and output to a host processor via the I²C serial bus. The recovered XDS data packet is further defined in the EIA-608 specification. The on-chip XDS filters in the Z86229 are fully programmable, enabling recovery of only those XDS data packets selected by the user. This functionality allows the device to extract the required XDS information with proper XDS filter setup for compatibility in a variety of TVs, VCRs, and Set-Top boxes.

In addition, the Z86229 is ideally suited to monitor Line 21 video displayed in a PiP window for violence blocking, CCD, and other XDS data services. A block diagram of the Z86229 is illustrated in Figure 1.

I²C-bus controlled BTSC stereo/SAP decoder TDA9850

FEATURES

- Quasi alignment-free application due to automatic adjustment of channel separation via I²C-bus
- Dbx noise reduction circuit
- Dbx decoded stereo, Second Audio Program (SAP) or mono selectable at the AF outputs
- Additional SAP output without dbx, including de-emphasis
- High integration level with automatically tuned integrated filters
- Input level adjustment I²C-bus controlled
- Alignment-free SAP processing
- Stereo pilot PLL circuit with ceramic resonator, automatic adjustment procedure for stereo channel separation, two pilot thresholds selectable via I²C-bus
- Automatic pilot cancellation
- Composite input noise detector with I²C-bus selectable thresholds for stereo and SAP off
- I²C-bus transceiver.

NJW1144 AUDIO PROCESSOR

GENERAL DESCRIPTION

The NJW1144 is a sound processor includes all of the functions required to process the audio signal for TV, such as tone control, balance, volume, mute, and AGC functions.

Also the NJW1144 performs BBE sound enhancement and SRS 3D Stereo. The BBE regenerates high definitive and nearly real sound, and SRS 3D Stereo regenerates 3D surround sound with only two speakers.

All of the internal stats and variables are controlled by I²C BUS interface.

FEATURES

- Operating Voltage 8 to 13V
- I²C BUS Interface
- BBE Sound Enhancement (Low Boost and High Boost: 15dB max.)
- Internal 6 Input Audio Selectors and Monitor Output
- The AGC circuit reduces volume difference among input sources.
- Variable AGC Compression Level via I²C (4-levels)
- SRS 3D Stereo and Simulated Stereo
- Variable Surround Effect Level via I²C
- Low Noise VCA
- Bi-CMOS Technology
- Package Outline SOP40

0. Warnings and Cautions

- ✓ WARNING indicates hazards that may lead to death or injury if ignored.
- ✓ CAUTION indicates hazards that may lead to injury or damage to property if ignored.



- 1) This product uses a high voltage (450 V max.). Do not touch the circuitry of this product with your hands when power is supplied to the product or immediately after turning off the power. Be sure to confirm that the voltage is dropped to a sufficiently low level.
- 2) Do not supply a voltage higher than that specified to this product. This may damage the product and may cause a fire.
- 3) Do not use this product in locations where the humidity is extremely high, where it may be splashed with water, or where flammable materials surround it. Do not install or use the product in a location that does not satisfy the specified environmental conditions. This may damage the product and may cause a fire.
- 4) If a foreign substance (such as water, metal, or liquid) gets inside the product, immediately turn off the power. Continuing to use the products it may cause fire or electric shock.
- 5) If the product emits smoke, an abnormal smell, or makes an abnormal sound, immediately turn off the power. If noting is displayed or if the display goes out during use, immediately turn off the power. Continuing to use the product as it is may cause fire or electric shock.
- 6) Do not disconnect or connect the connector while power to the product is on. It takes some time for the voltage to drop to a sufficiently low level after the power has been turned off. Confirm that the voltage has dropped to a safe level before disconnecting or connecting the connector. Otherwise, this may cause fire, electric shock, or malfunction.
- 7) Do not pull out or insert the power cable from/to an outlet with wet hands. It may cause electric shock.
- 8) Do not damage or modify the power cable. It may cause fire or electric shock.
- 9) If the power cable is damaged, or if the connector is loose, do not use the product; otherwise, this can lead to fire or electric shock.
- 10) If the power connector or the connector of the power cable becomes dirty or dusty, wipe it with a dry cloth. Otherwise, this can lead to fire.

Product Specification of PDP Module



General

- 1) Do not place this product in a location that is subject to heavy vibration, or on an unstable surface such as an inclined surface. The product may fall off or fall over, causing injuries.
- 2) When moving the product, be sure to turn off the power and disconnect all the cables. While moving the product, watch your step. The product may be dropped or fall, leading to injuries or electric shock.
- 3) Do not place this product in a location that is subject to heavy vibration, or on an unstable surface such as an inclined surface. The product may fall off or fall over, causing injuries.
- 4) Before disconnecting cable from the product, be sure to turn off the power. Be sure to hold the connector when disconnecting cables. Pulling a cable with excessive force may cause the core of the cable to be exposed or break the cable, and this can lead to fire or electric shock.
- 5) This product should be moved by two or more persons. If one person attempts to carry this product alone, he/she may be injured.
- 6) This product contains glass. The glass may break, causing injuries, if shock, vibration, heat, or distortion is applied to the product.
- 7) The temperature of the glass surface of the display may rise to 80°C or more depending on the conditions of use. If you touch the glass inadvertently, you may be burned.
- 8) Do not poke or strike the glass surface of the display with a hard object. The glass may break or be scratched. If the glass breaks, you may be injured.
- 9) If you glass surface of the display breaks or is scratched, do not touch the broken pieces or the scratches with bare hands. You may be injured.
- 10) Do not place an object on the glass surface of the display. The glass may break or be scratched.

Product Specification of PDP Module

USE

- 1) Because this product uses a high voltage, connecting or disconnecting the connectors while power is supplied to the product may cause malfunctioning. Never connect or disconnect the connectors while the power is on. Immediately after power has been turned off, a residual voltage remains in the product. Be sure to confirm that the voltage has dropped to a sufficiently low level.
- 2) Watching the display for a long time can tire the eyes. Take a break at appropriate intervals.
- 3) PDP 's brightness and contrast ratio is lower than that of the CRT. The picture is dimmer with surrounding light and better for viewing in dark condition.
- 4) Do not cover or wrap the product with a cloth or other covering while power is supplied to the product.
- 5) Before turning on power to the product, check the wiring of the product and confirm that the supply voltage is within the rated voltage range. If the wiring is wrong or if a voltage outside the rated range is applied, the product may malfunction or be damaged.
- 6) Do not store this product in a location where temperature and humidity are high. This may cause the product to malfunction. Because this product uses a discharge phenomenon, it may take time to light (operation may be delayed) when the product is used after it has been stored for a long time. In this case, it is recommended to light all cells for about 2hours (aging).
- 7) If the glass surface of the display becomes dirty, wipe it with a soft cloth moistened with a neutral detergent. Do not use acidic or alkaline liquids, or organic solvents.
- 8) Do not tilt or turn upside down while the module package is carried, the product may be damaged.
- 9) This product is made from various materials such as glass, metal, and plastic. When discarding it, be sure to contact a professional waste disposal operator.

Repair and Maintenance

Because this product combines the display panel and driver circuits in a single module, it cannot be repaired or maintained at user's office or plant. Arrangements for maintenance and repair will be determined later

1. GENERAL DESCRIPTION

□ DESCRIPTION

The PDP42V6##### is a 42-inch 16:9 color plasma display module with resolution of 852(H) × 480(V) pixels. This is the display device which offers vivid colors with adopting AC plasma technology by LG Electronics Inc.

□ FEATURES

High peak brightness (1000cd/m² Typical) and high contrast ratio (3000:1 Typical) enables user to create high performance PDP SETs.

□ APPLICATIONS

- ✓ Public information display
- ✓ Video conference systems
- ✓ Education and training systems



Product Specification of PDP Module

□ ELECTRICAL INTERFACE OF PLASMA DISPLAY

The PDP42V6##### requires only 8bits of digital video signals for each RGB color.

In addition to the video signals, six different DC voltages are required to operate the display.

The PDP42V6##### is equipped with P-CUBE function which analyzes display signals to optimize system control factor for showing the best display performance.

□ GENERAL SPECIFICATIONS

- ✓ Model Name : PDP42V6##### (42V6##### Model)
- ✓ Number of Pixels : 852(H) × 480(V) (1pixel=3 RGB cells)
- ✓ Pixel Pitch : 1080μm (H) × 1080μm (V)
- ✓ Cell Pitch : 367μm (H) × 1080μm (V) (Green Cell basis)
- ✓ Display Area : 920.1(H) × 518.4(V) ±0.5mm
- ✓ Outline Dimension : 1005(H) × 597(V) × 61(D)±1mm
- ✓ Pixel Type : RGB Closed type
- ✓ Number of Gradations : (R)256 × (G)256 × (B)256 (16.7 Mega colors)
- ✓ Weight : 14.8 Kg ± 0.5 Kg (Net 1EA)
111 Kg ± 5 Kg (5EA/1BOX)
- ✓ Aspect Ratio : 16:9
- ✓ Peak Brightness : Typical 1000cd/m² (1/25 White Window)
- ✓ Contrast Ratio : Average 60:1 (In a bright room with 150Lux at center)
: Typical 3000:1 (In a dark room 1/25 White Window pattern at center)
- ✓ Power Consumption : Typical 220 W (Full White)
- ✓ Life-time : more than 60,000 Hours of continuous operation

Life-time is defined as the time when the brightness level becomes half of its initial value.

✓ Display Dot Diagram

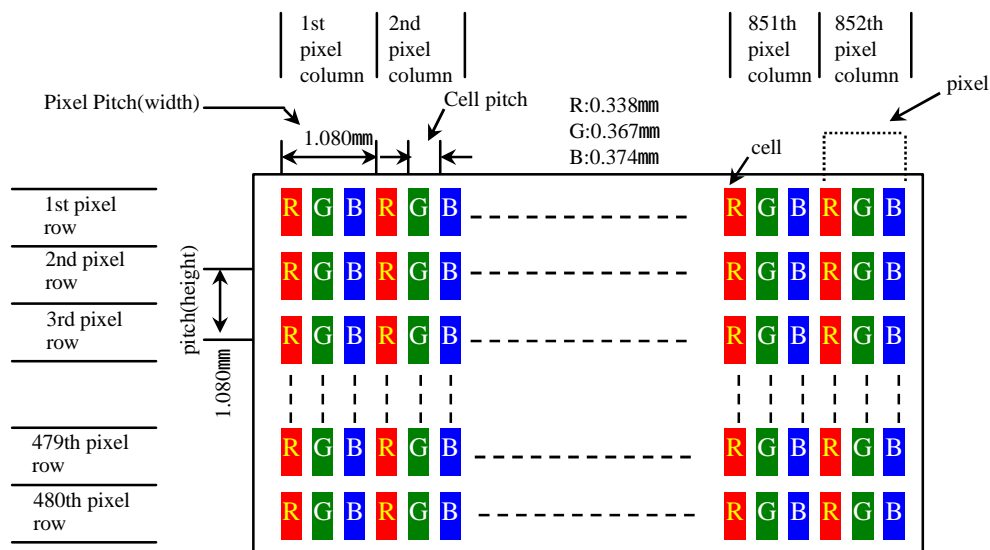

7. CONNECTORS and CONNECTIONS

❑ Power Input Connector

➤ Connector P3001 Pin Assignment

Pin No.	Symbol	Pin No.	Symbol
1	Vs	5	GND
2	Vs	6	Va
3	nc	7	GND
4	GND	8	+5V

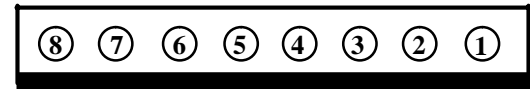

1-1123723-8 Pin numbers
(Top View, viewed from the pin connection side)

- ✓ Module side connector : 1-1123723-8 (Header)
- ✓ Mating Connector : 1-1123722-8 (Housing)
- ✓ Connector Supplier : AMP

➤ Connector P2005 Pin Assignment

Pin No.	Symbol	Pin No.	Symbol
1	VS	6	GND
2	VS	7	GND
3	VS	8	GND
4	nc	9	nc
5	GND	10	nc

- ✓ Module side connector : 1-1123723-10 (Header)
- ✓ Mating Connector : 1-1123722-10 (Housing)
- ✓ Connector Supplier : AMP

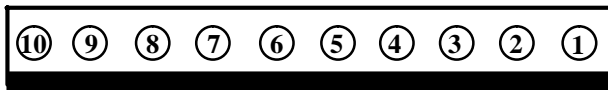

1-1123723-10 Pin numbers
(Top View, viewed from the pin connection side)

➤ Connector P2006 Pin Assignment

Pin No.	Symbol	Pin No.	Symbol
1	GND	3	5V
2	GND	4	5V

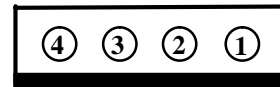

1-1123723-4 Pin numbers
(Top View, viewed from the pin connection side)

- ✓ Module side connector : 1-1123723-4 (Header)
- ✓ Mating Connector : 1-1123722-4 (Housing)
- ✓ Connector Supplier : AMP

8. Input/Output pin assignment & specification

CN808

#1 ~ #4 : +5Vctrl
#5 ~ #8 : GND

CN805

#1 ~ #2 : 5Vctrl
#3 ~ #4 : GND

CN806

#1 : Va
#2 : Va
#3 : GND
#4 : GND
#5 : GND
#6 : GND
#7 : NC
#8 : Vs
#9 : Vs
#10 : Vs

CN807

#1 : Vs
#2 : Vs
#3 : NC
#4 : GND
#5 : GND
#6 : Va
#7 : GND
#8 : +5V

CN804

#1 : 9Vsc
#2 : 9Vsc
#3 : GND
#4 : 5Vsc
#5 : 5Vsc
#6 : 5Vsc
#7 : GND
#8 : GND
#9 : GND

CN803

#1 ~ #3 : 5Vsc
#4 ~ #6 : GND
#7, #8 : 12Vsc
#9, #10 : GND
#11, #12 : NC

CN809

#1 : 9Vsc
#2 : GND

CN802

#1 ~ #2 : 30V or 24V
#3 ~ #4 : GND

Selection S/W

24V 30V

CN801

#1 : ACD
#2 : RLY ON
#3 : 5Vst_by
#4 : GND
#5 : Vs ON
#6 : 5VD
#7 : NC

Location No.	Specification	Vendor
CN01	3-176976-2(Red)	AMP
CN02	3-176976-1(Natural)	AMP
CN03	3-176976-1(Natural)	AMP
CN801	171825-7	AMP
CN802	171825-4	AMP
CN803	1-171825-2	AMP
CN804	171825-9	AMP
CN805	1-1123723-4	AMP
CN806	1-1123723-0	AMP
CN807	1-1123723-8	AMP
CN808	171825-8	AMP
CN809	171825-2	AMP

*** PSU operation method S/W**

CN01

From inlet

CN02

Live
Neutral

CN03

Live
Neutral

Before connecting with S/W : After connecting with S/W

9. Adjustment detail

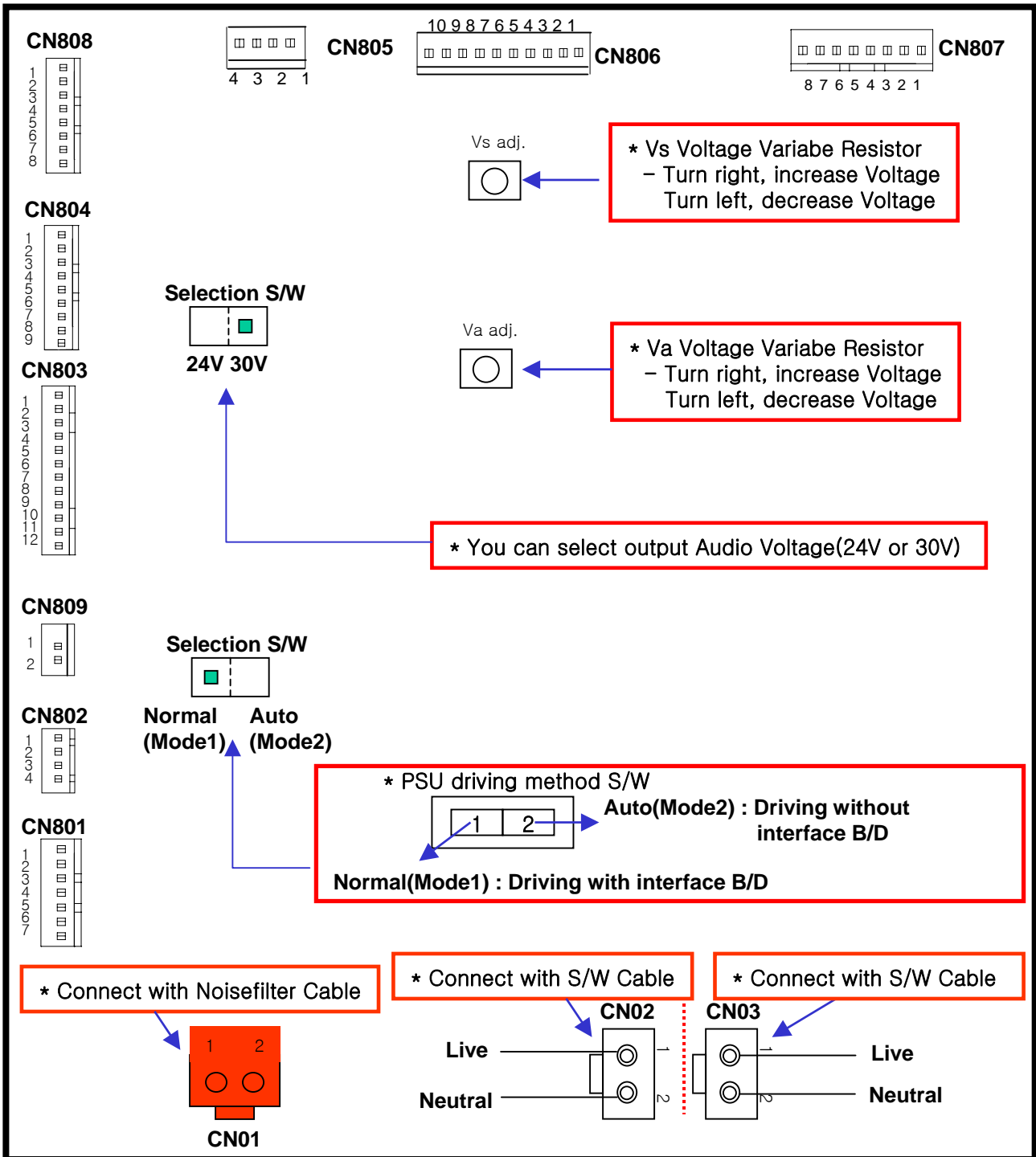

※ The color of CN01 is red.(The color of CN02, CN03 are natural.)

8. LABEL

□ LABEL Sticking Position

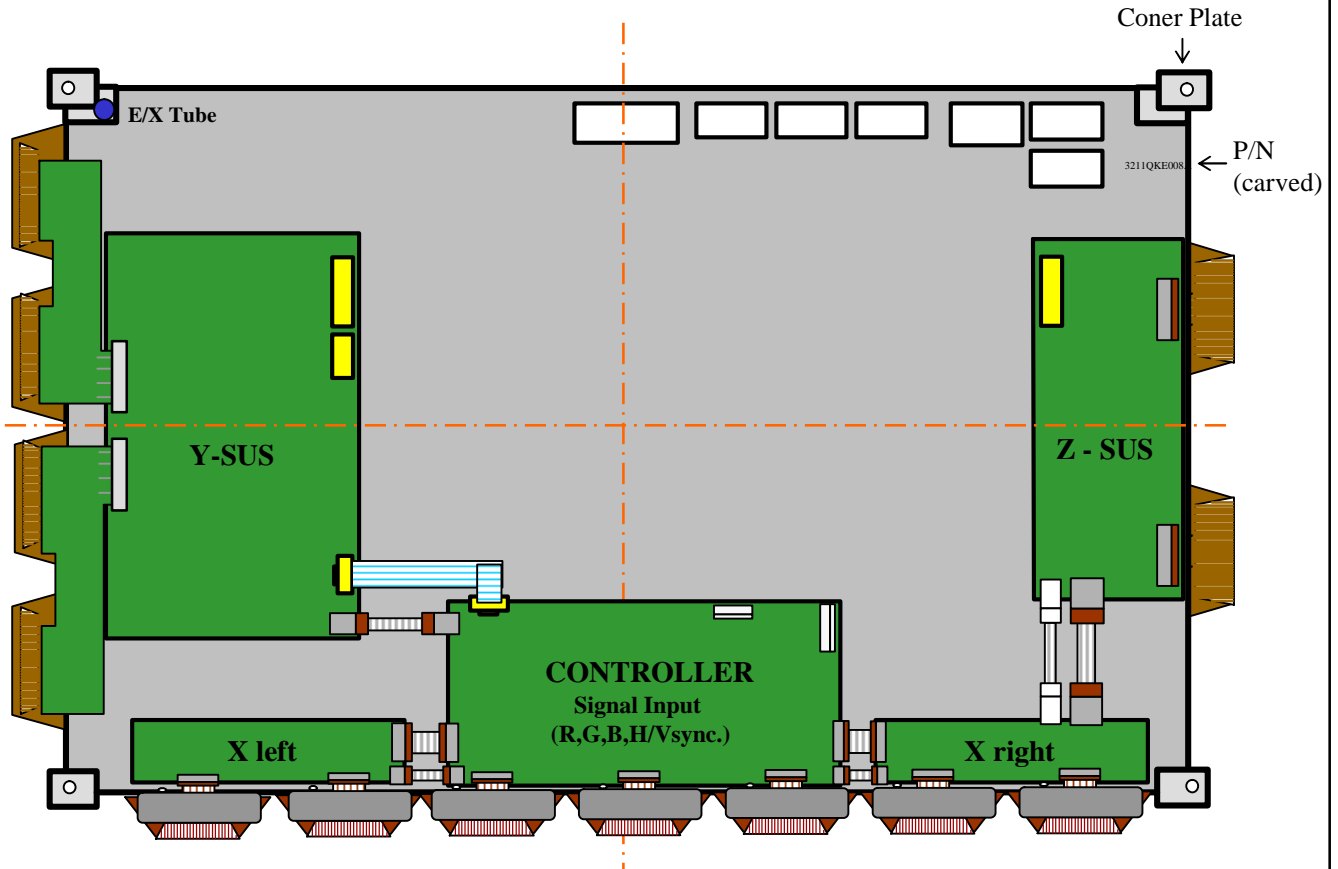

□ Identification Label : LABEL



- Model Name
- Bar Code (Code 128, Contains the manufacture No.)
- Manufacture No.
- The trade name of LG Electronics
- Manufactured date (Year & Month)
- Manufactured place

Trouble Shooting Manual of PDP Module

- Introduction**
- Precautions**
- Basic**
- Trouble shooting**

1. Introduction

COMPOSITION OF PDP BOARDS

● 42" V6 MODEL.

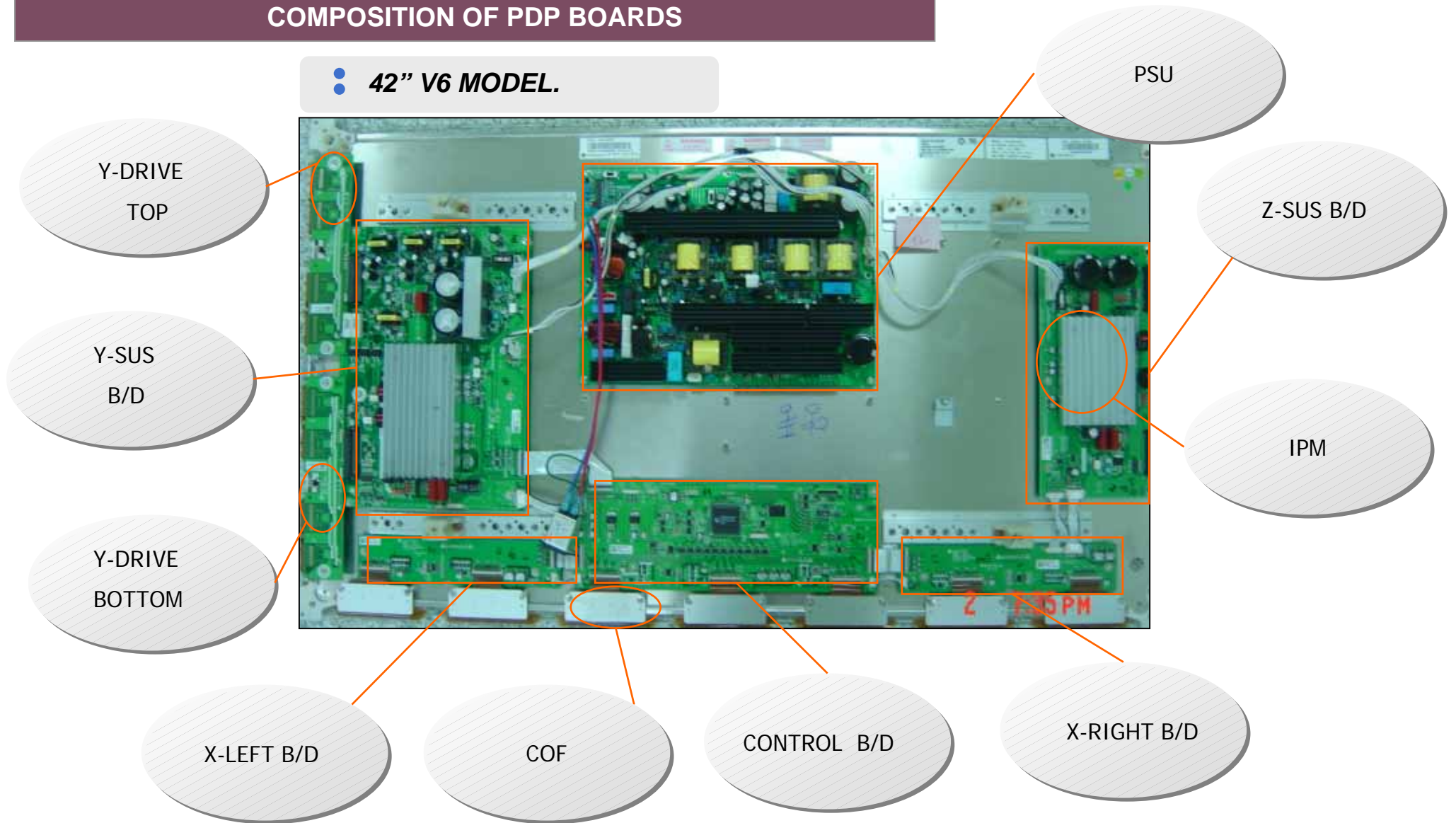

1. Introduction

• Definitions

Definition of MODULE position

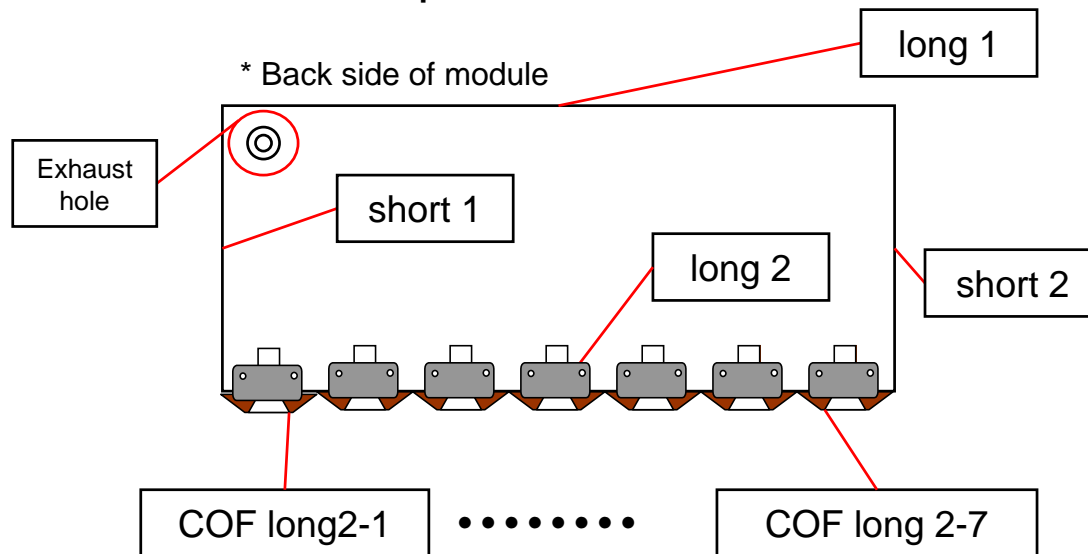

Identification label



Model Name
Bar Code (Code 128, Contains the manufacture No.)
Manufacture No.
The trade name of LG Electronics
Manufactured date (Year & Month)
The place Origin
Model Suffix

1. Introduction

Voltage label (Attached on back side of module)

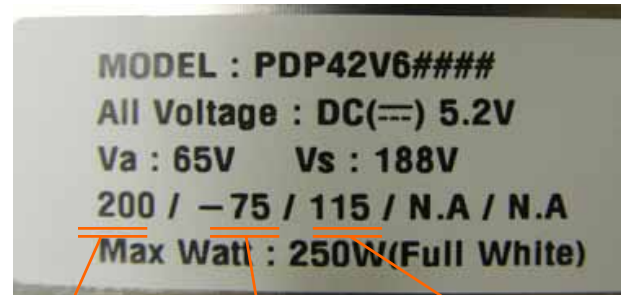

Vsetup

-Vy

Vsc

Part No. label (Attached on board)



PCB PART NO.

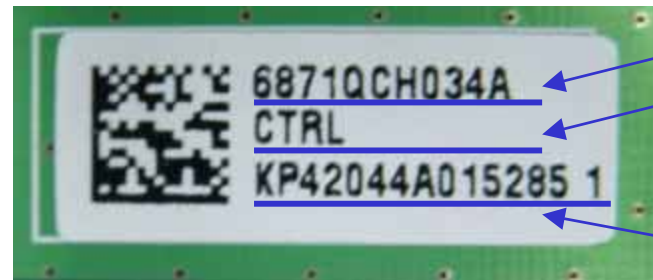

BOARD ASS'Y
PART NO.

BOARD NAME

BOARD SERIAL NO.



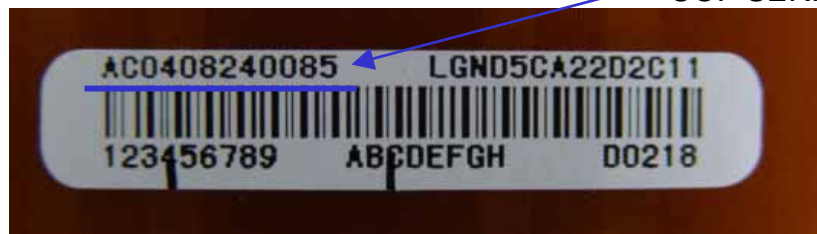

COF serial No. label (attached on COF)



COF SERIAL NO.

1. Introduction

Terms of defect

Term	Appearance
Add short (line on)	
Add open (line off)	
Sus short (line on)	
Sus open (line off)	

2. Precaution

• *Safety precautions*

Be sure to read this before service. When using/ handling this PDP module, Please pay attention to the below warning and cautions.

1. Before repairing there must be a preparation for 10 min.
2. Do not impress a voltage that higher than represented on the product.
3. Since PDP module uses high voltages, Be careful a electric shock and after removing power some current remains in drive circuit. so you can touch circuit after 1 min.
4. Drive circuits must be protected from static electricity.
5. The PDP module must be Moved by two man.
6. Be careful with short circuit of PDP boards when measuring any voltages.

• *Before request service*

1. Check panel surface and appearance of B/D.
 2. Check the model label. Whether it is boards of same model with label.
 3. Before requesting Service, please inform us a detail defect phenomenon and history of module. it can be helpful to us for a smooth sevice.
- Ex) COF long 2-1 fail ,address 1 line open, Y b/d problem , mis-discharge.

2. Precaution

- *Handle with care (COF)*

COF is the most important component in the PDP module.

Even a little imperfection of COF can make a serious screen problem.



SCRATCHING

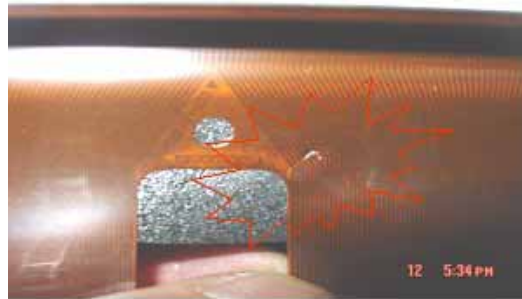

TEARING



BEING PUSHED

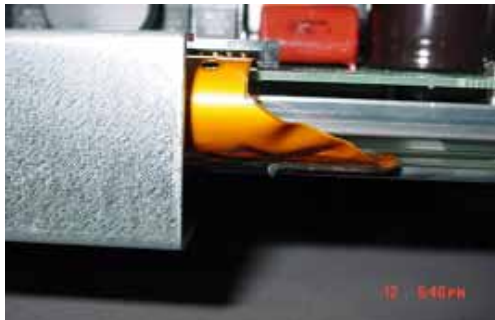

BENDING

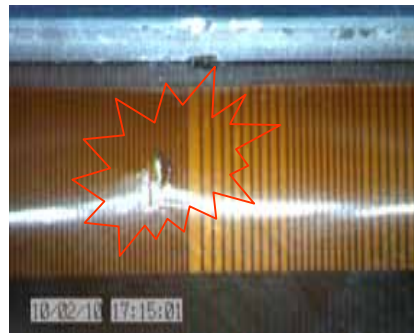

CHOPING

3. Basic

1. X B/D

: receiving LOGIC signal from CONTROL B/D and make ADDRESS PULSE(generates Address discharge)by ON/OFF operation, and supplies this waveform to COF(data)



X LEFT B/D

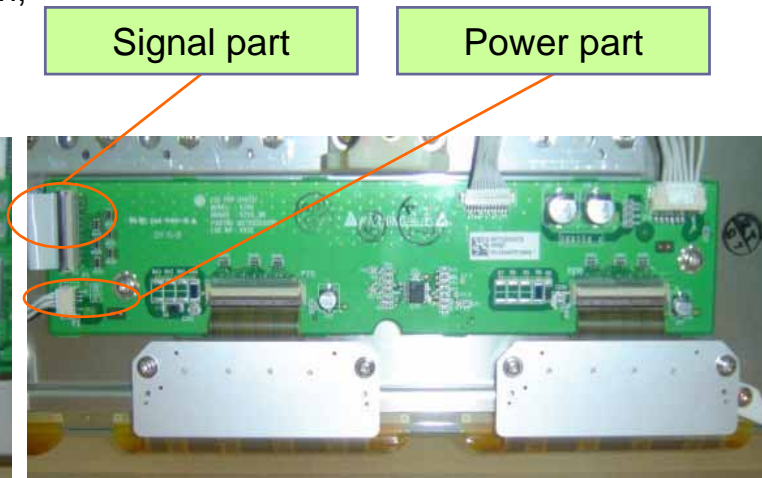

X RIGHT B/D

<COF Separating>

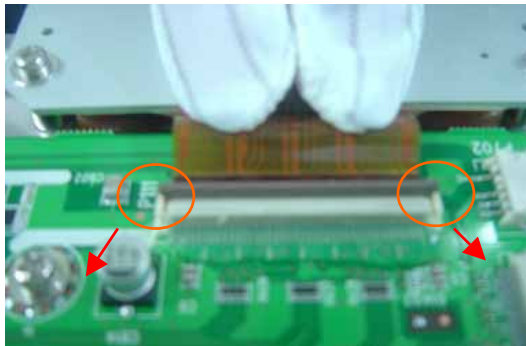

Lift up lock as shown in narrow.

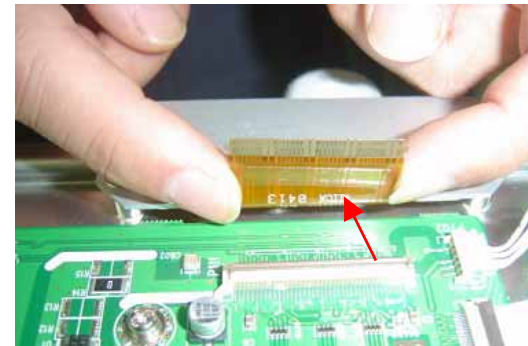

Pull COF as shown in narrow.

3. Basic

2. Z sustain B/D

: make SUSTAIN PULSE and ERASE PULSE that generates SUSTAIN discharge in panel by receiving LOGIC signal from CONTROL B/D.

this waveform is supplied to panel through FPC(Z).

*composed with IPM,FET,DIODE, electrolytic capacitor ,E/R coil.

* IPM (Intelligent Power Module)
E/R(Energy recovery)

<FPC Separating>



Separate the fixed Screw of Z-Board.
Pull out Lock as shown in arrow.

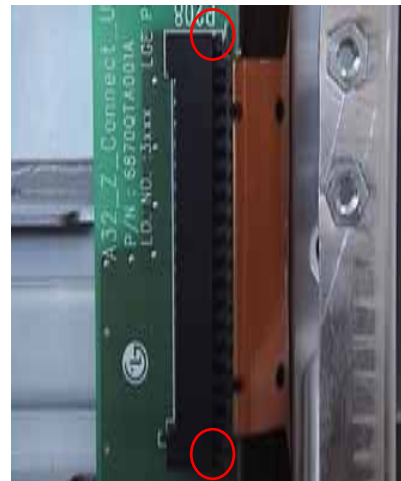

Condition in Lock part is pulled

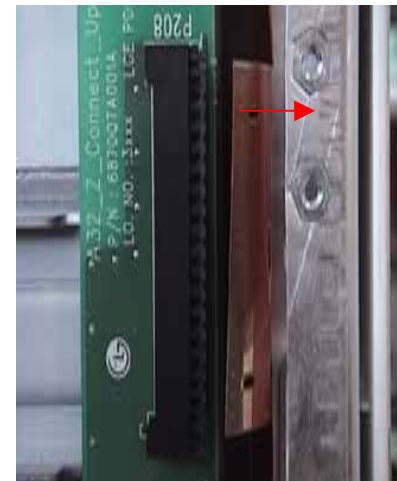

Pull FPC Connector
as shown in arrow.



3. Basic

3. Y drive B/D

- 1) This is a path to supply SUSTAIN ,RESET waveform which made from Y SUSTAIN B/D to panel through SCAN DRIVER IC.
- 2) Supply a wave form that select Horizontal electrode (Y SUSTAIN electrode) sequentially.
 - potential difference is 0V between GND and Vpp of DRIVER IC in SUSTAIN period.
 - being generated potential difference between GND and Vpp only in SCAN period.

* In case of 42" V6 use DRIVER IC IC 8 EA (TOP, BOTTOM: each 4EA)



3. Basic

4. Y sustain B/D

: generates SUSTAIN,RESET waveform, V_{sc} (SCAN)voltage.
and supplies it Y DRIVER B/D.

* Composed with IPM,DIODE, electrolytic capacitor ,FET.

5. Control Board

: creates signal processing (Contour noise,reduction ISM,..)
and an order of many FET on/off of each DRIVER B/D with
R,G,B each 8bit input.

* Use 3.3V/5V 2 kinds of power .



3. Basic

6. DC/DC Converter part

: Being impressed 5V, V_a , V_s ,

DC/DC converter makes

5V, V_a , V_s , V_{set_up} , V_{sc}

which is essential for each B/D.

There is no DC/DC B/D in

model 40" /42" (1 POWER B/D).

* 50" 60" embedded DC/DC B/D
separately because of high power
consumption.



3. Basic

7. FPC (Flexible Printed Circuit)

: supply a driving waveform to PANEL by connecting a PAD electrode of PANEL with PCB(Y and Z).

* there is two type of this for Y B/D. One is single-sided, another is double-side. These are having pattern on it

* for Z B/D, there is no pattern , single-sided, and Beta type(all of copper surface).



8. FFC (Flat Flexible Cable)

: for connecting a Logic signal between B/D and B/D.

*There is 0.5mm pitch,50pin type

1mm pitch ,30pin type.

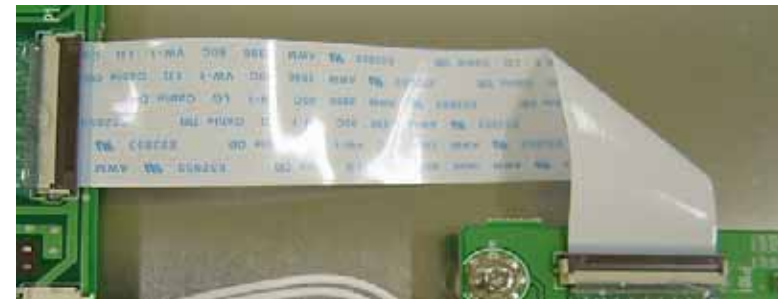

3. Basic

9. COF (Chip On Film)

: supply a waveform which made from X B/D to panel and select a output pin that is controlled by COF when be on or off.

96 output pin per IC.

the more the resolution higher, the less spare space where can set IC on it in B/D. without using IC PACKAGE, we can use a BARE IC , so we can get IC with LOW COST because we do not solder IC on PCB directly, a soldering defect rate decrease.

* composition

1) FPC + Heat /Sink

⇒ FPC for COF must have a Low Spec decline with getting damp

2) CHIP resistor + CHIP CAPACITOR

3) BARE IC (STV7610A/WAF) + GOLD WIRE/AL WIRE

4) EPOXY MOLDING

Bare IC

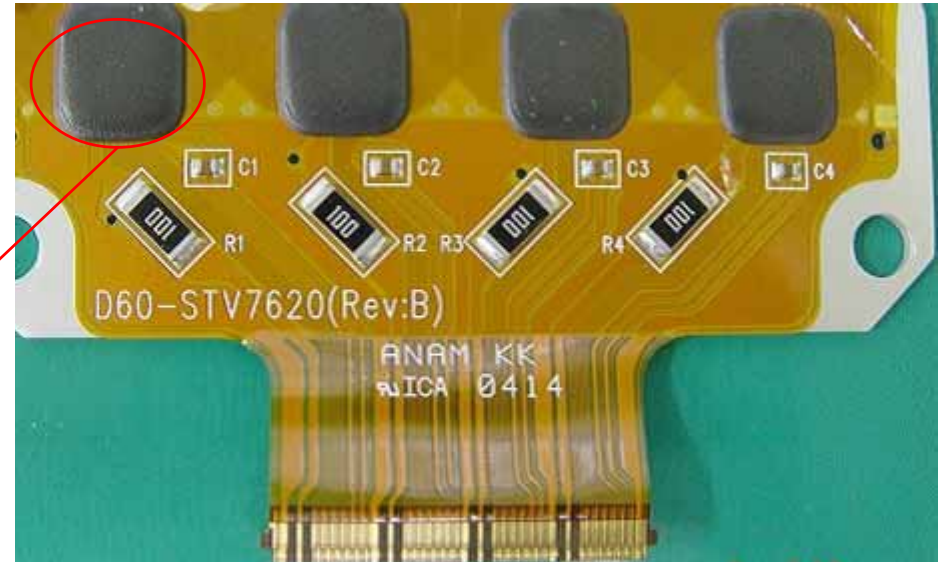

* 42 V6 COF is the same as 42V5.

3. Basic

10. IPM(Intelligent Power Module)

: composition

HEATSINK,CAPACITOR

DIODE

IC LINEAR

RESISTOR,TRANSISTOR,FETS.

: description

Attached at Z B/D and Y B/D, make Sustain waveform.

Sustainer : supply a square wave to panel to make a video.

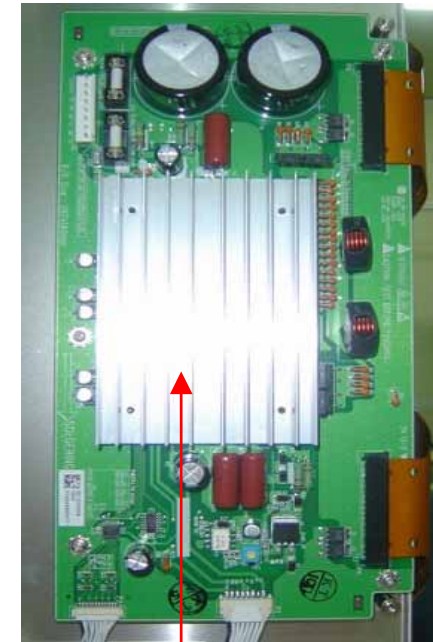
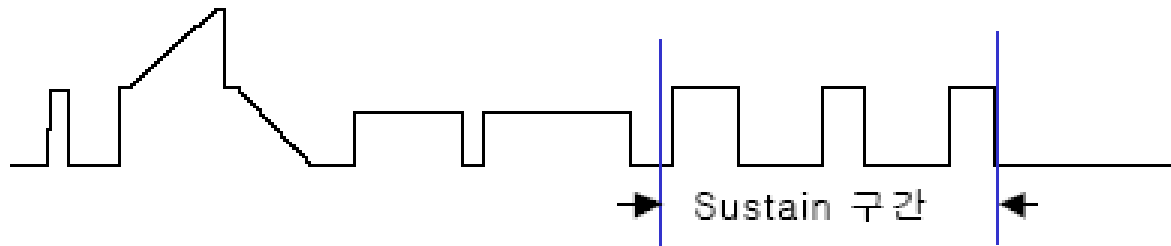

IPM

4. Trouble shooting.

• Fast check up

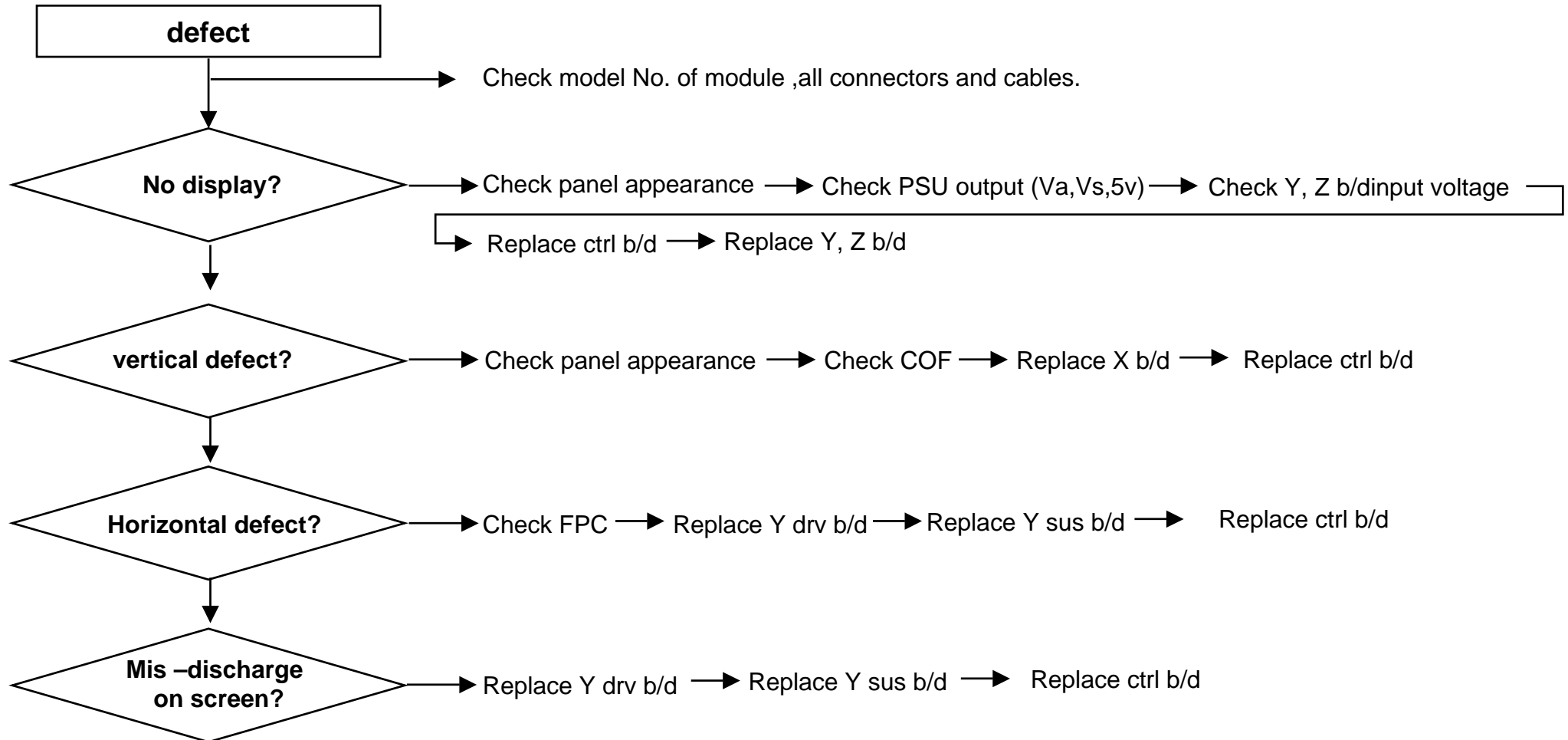

4. Trouble shooting.

• Logical judgment

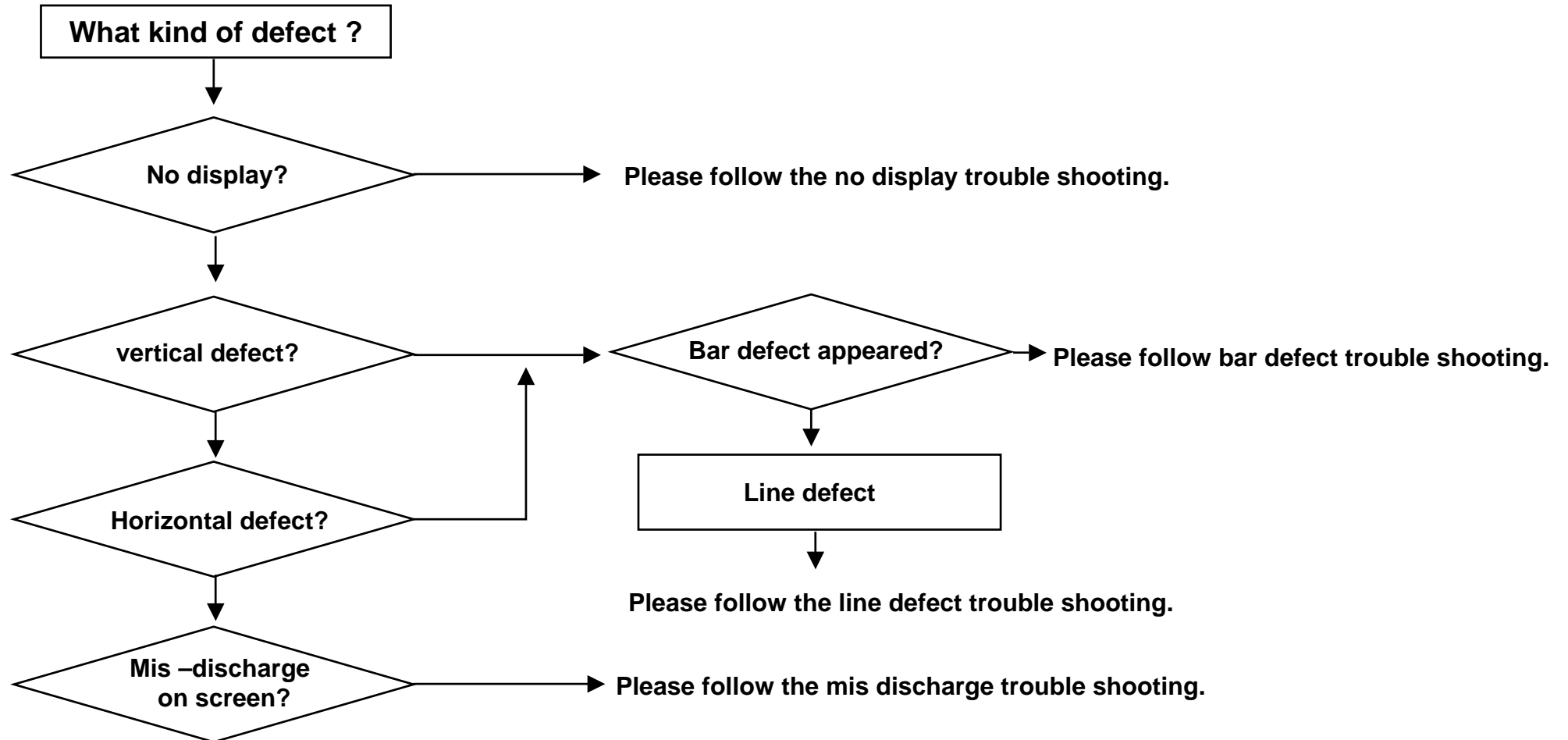

4. Trouble shooting.

• *No display*

Check each section with following method if there is problem, replace or repair that part.

If not go to the next section.

1. Connector

Confirm every Connector (PSU, Y-SUS, CTRL, Z-SUS)

module may not be normal by mis-connection which can not send signal and power.

Also Mis connection for a long time has a specific b/d failed.



CTRL B/D + Y-SUS

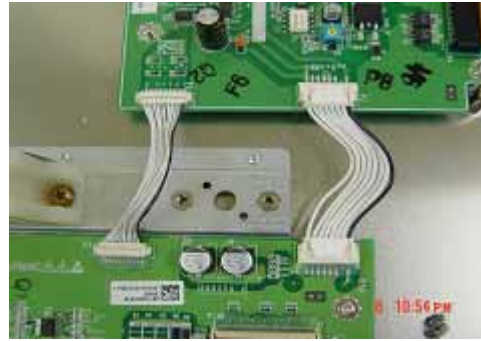

CTRL B/D + Z-SUS



CTRL B/D + X-B/D

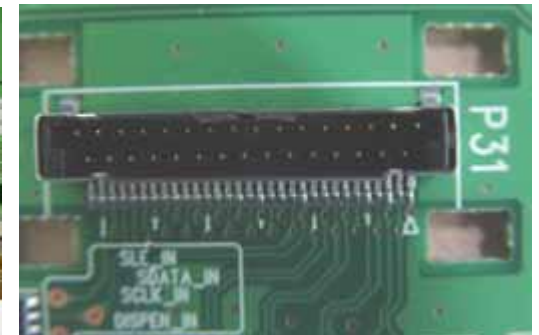

Signal input(LVDS)

4. Trouble shooting.

2. Exhaust tip Crack

Confirm exhausting Tip and find Crack with naked eyes to check vacuum state.

If there is problem replace the module .

in case of vacuum breakdown, module makes a shaking noise because of inside gas ventilation.

(there may be a small crack which could not see with naked eyes. And this noise is different from Capacitor noise.)

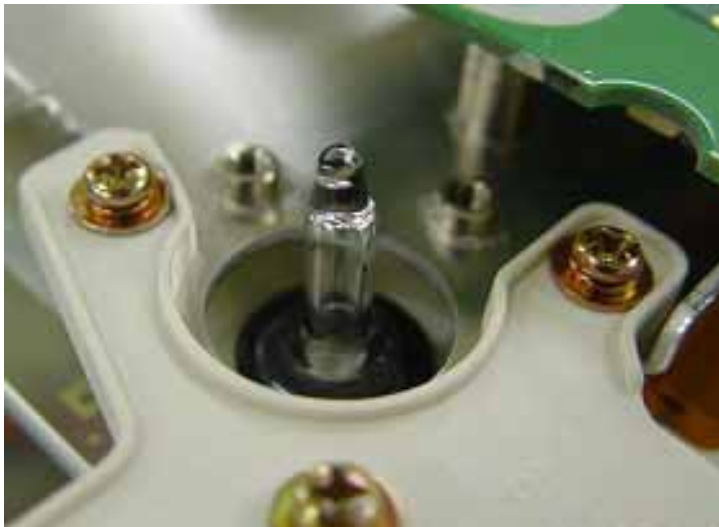

NORMAL

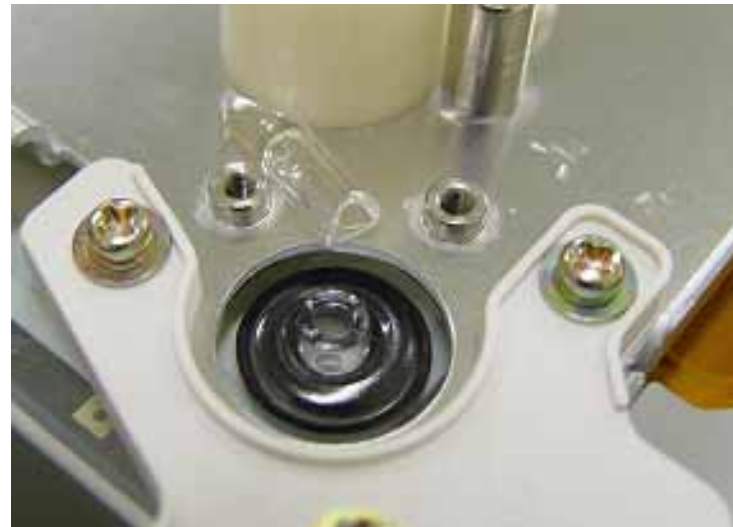

CRACKED

4. Trouble shooting.

3. PSU(Power Supply Unit)

1. Check each unit part of PSU inside with naked eyes.
(capacitor, FET, a kind of IC, resistor)
2. Check FUSE and SW1 (on Normal).
3. Check Output voltage which is converted from AC V to DC V.

voltage Check (5V, Va, Vs)

When PSU Protection occurred. Check Short between Y-SUS, Z-SUS B/D .

Confirm
input voltage

if not same

Adjust
voltages



Multi-meter Touch point
(5V, Va, Vs must accord with Module Label)

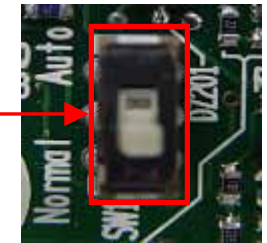
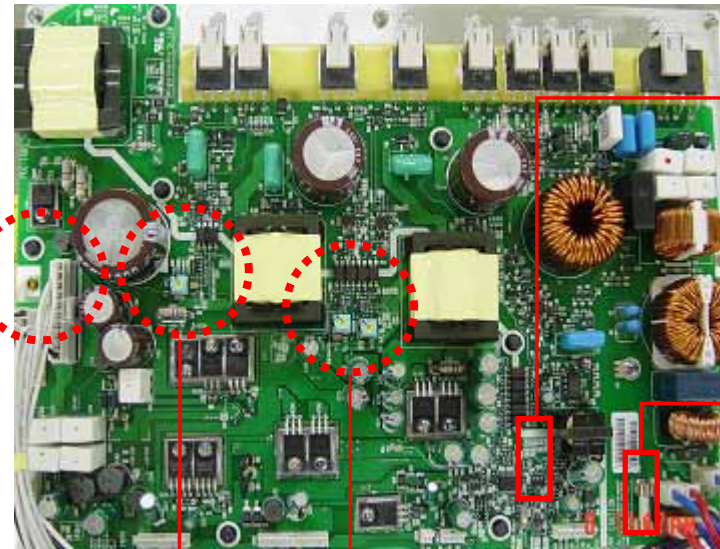

SW1 Normal

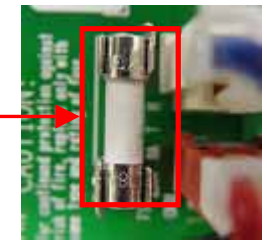

Fuse open check

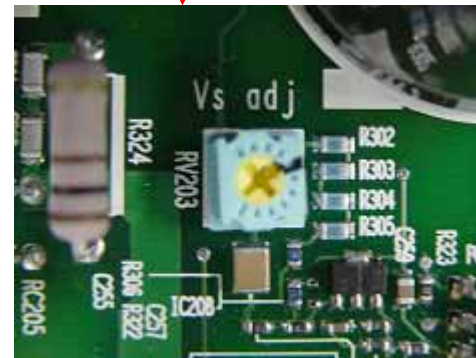

Vs Voltage ADJ
(Vs : About 180 ~195 V)

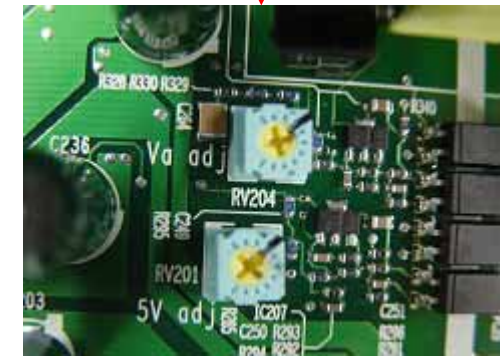

Va, 5V(VCC) Voltage ADJ
Va : About 55 ~65 V
5V(VCC) : 5V~5.5V)

4. Trouble shooting.

4. Ctrl B/D

1. Confirm LED D17(flashing) ,13 lighting
2. If not CHECK OSC X1 output.
3. Check CTRL input voltage (CONNECTOR P300)
4. CHECK 3.3V, 5V,15V.
5. Check IC 11 3.3V
IC 3 2.5V

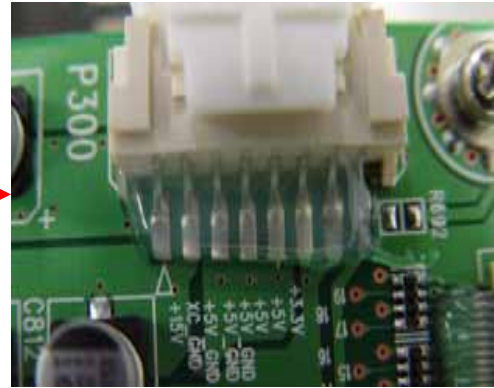

Diode

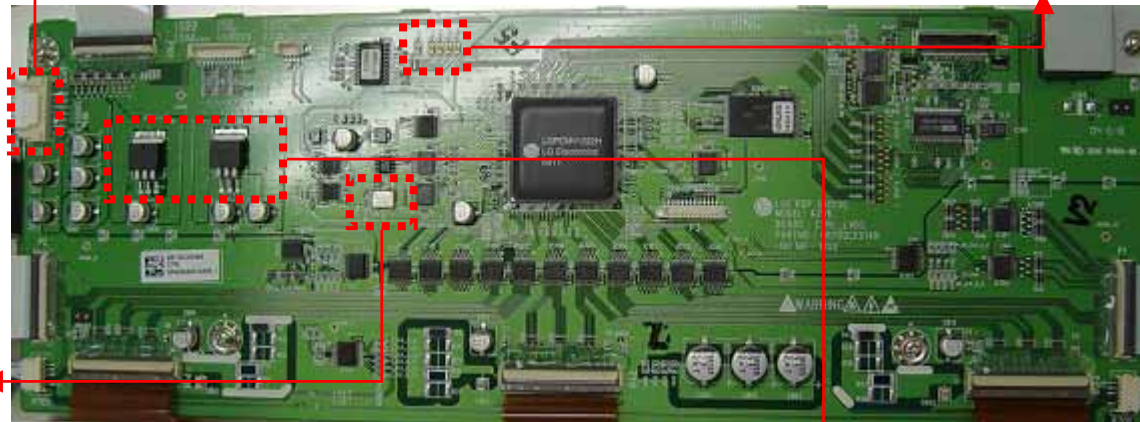
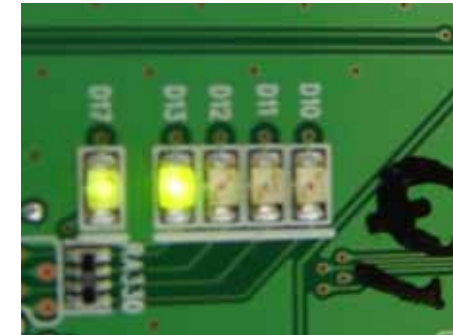

OSC(X1)

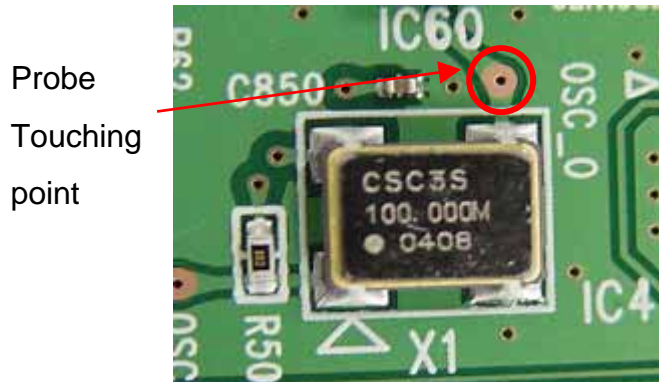

Check oscillating state.
(normal 100 MHZ)

Be careful with physical shock.

Check IC 11,13

DMM +
DMM - (GND)



4. Trouble shooting.

5. Y-sus B/D

1. Check FUSE [FS1(5v) ,FS2(Vs)].
2. Check voltages(Vsetup,-Vy, Vscw)
3. Check DIODE between GND and Y SUS output.
[SUSUP(OC2) SUSDN(OC1)].
forward=0.4 ,reverse=OVERLOAD.
4. Check whether output voltages agrees
with voltage that represented in label.

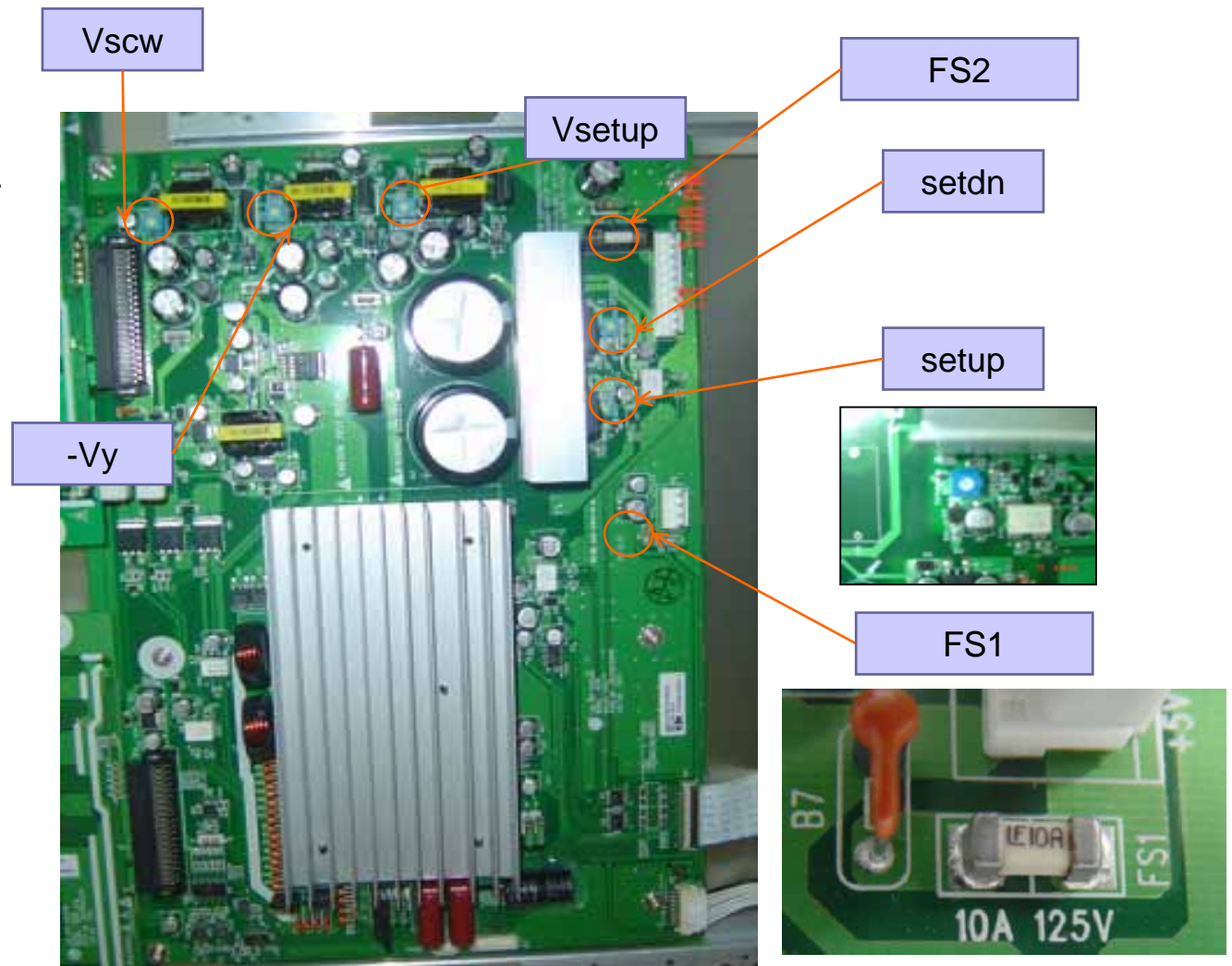

4. Trouble shooting.

Check whether output voltages agrees with voltage that represented in label.

Check diode value GND between Y-SUS output.



Normal diode value= 0.4 (forward)

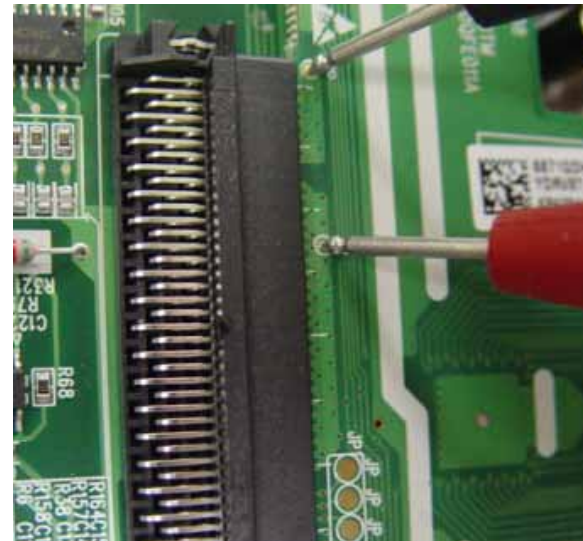

Normal diode value = OL (reverse)

4. Trouble shooting.

6. Z-sus B/D

1. Check the FUSE.
2. Check input voltages.(Va, 5V,15V)
3. Check FPC out put diode value.
4. Check ramp waveform.

Check the FUSE

5V FUSE

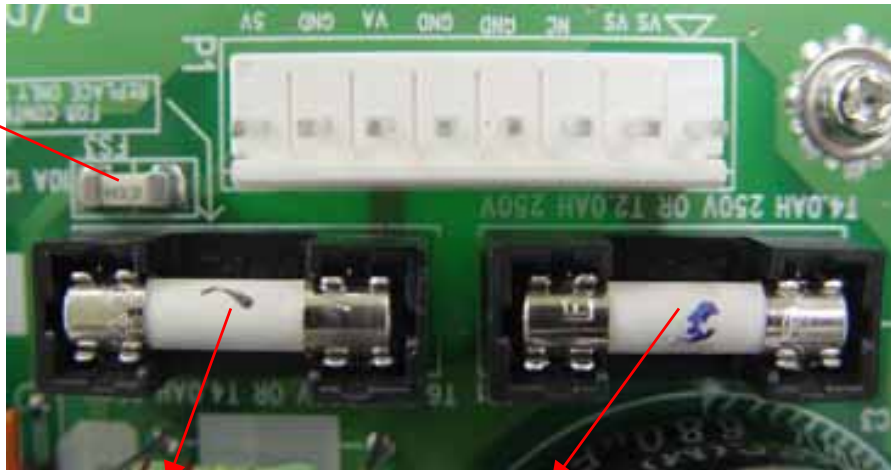

Check input voltages

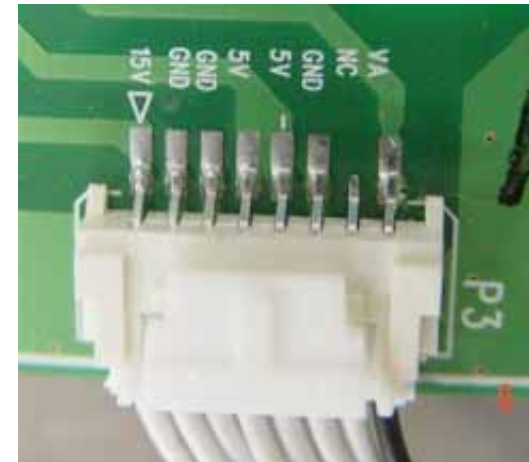

4. Trouble shooting.

Variable resistance of Z RAMP
waveform slope.

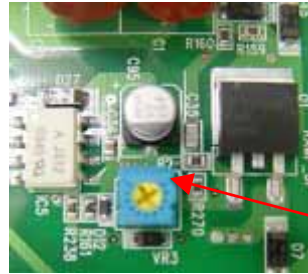

Check FPC output diode value.

caution: check certainly after removing FPC.



Normal diode value=0.375(forward)



Normal diode value=OVER LOAD(reverse)

4. Trouble shooting.

Power protection

It is power protection when power is off automatically within 2~3 min. from power on.

Power protection function protect the boards when occurred short on circuits of PDP module or power problem.

If can not impress power even after replacing PSU, find out where the short occurred.

* PSU makers.

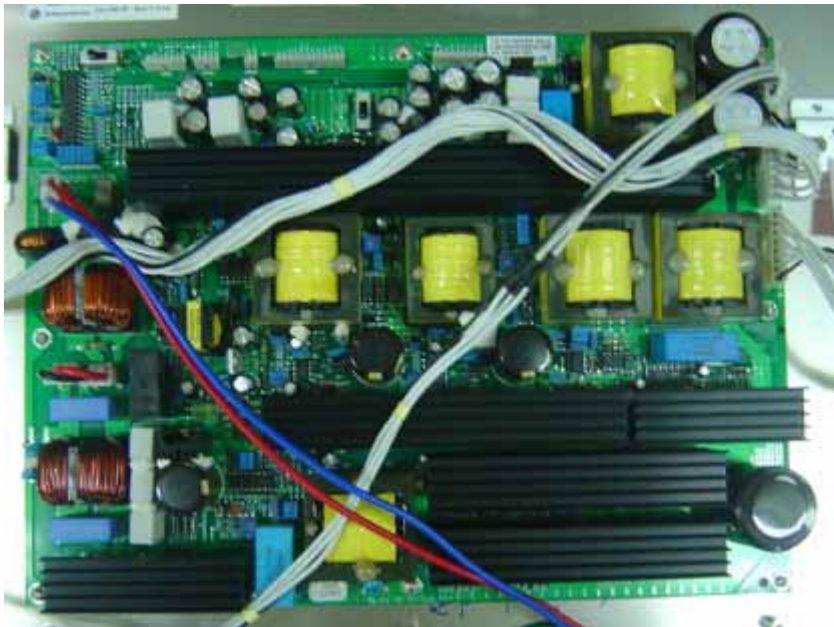

DAEGIL PSU



UNICON PSU

4. Trouble shooting.

• Vertical defect (bar)

Check each section with following method if there is problem, replace or repair that part.

If not go to the next section.

1. Connector

Check COF connector.

If not connected well, it will Make a bar defect .

Check here



Bar

Check here

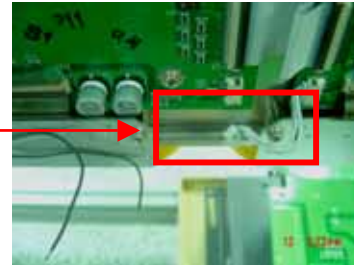

Off

2. Checking COF

Confirm whether COF was torn. And then check input of COF resistor and IC.

Tearing

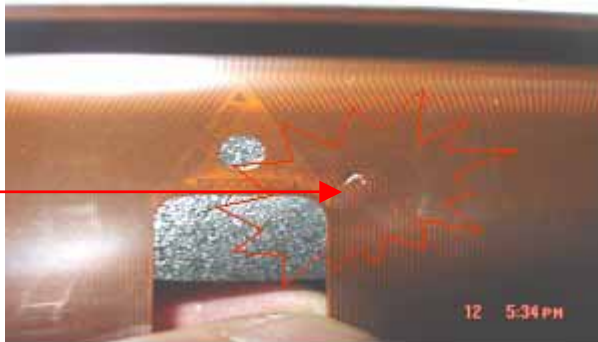

COF 6 is torn partly



4. Trouble shooting.

Checking address COF input of resistor and IC

COF resistor checking

Check the both side of resistor With Digital multi meter(DMM) .

If the resistor is normal, the resistor value will be 10.2 ~ 10.8

But if not, the value will be 0 or infinity and replace the resistor.

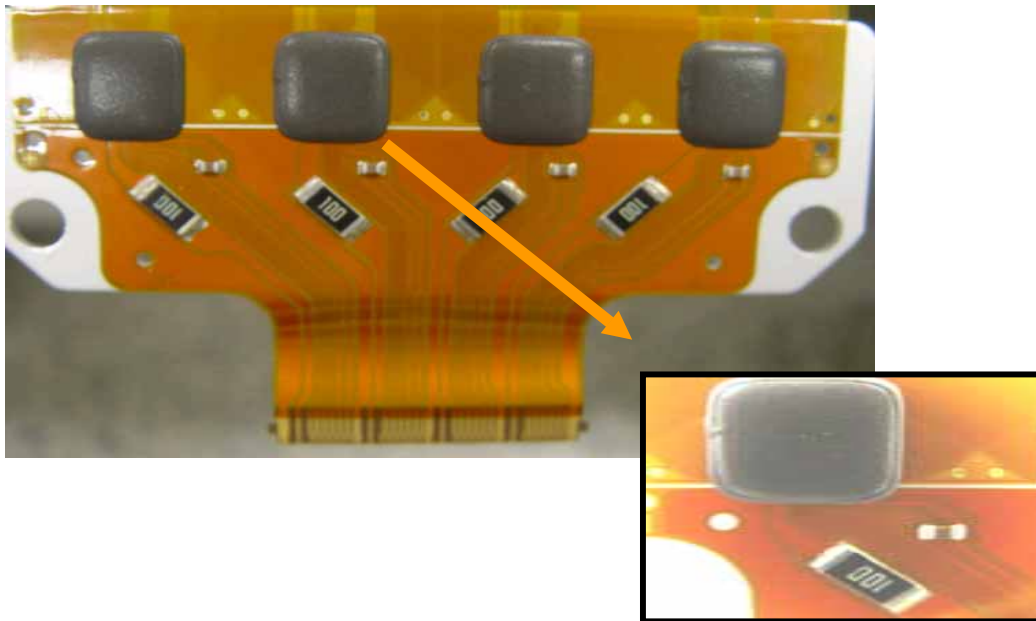

4. Trouble shooting.

Checking address COF input of resistor and IC

IC input checking

Inside of IC , there is 4 ea diodes which separated in 2 series .

(input 2, output 2)

*how to check

1.contact DMM - terminal to a right terminal of condenser(GND)

and DMM + terminal to a right terminal of IC, normal value 0.66 (fig.1)

2.contact DMM - terminal to Output terminal of resistor, and

DMM + terminal to a right terminal of IC , normal value 0.73 (fig.2)

Fig. 1

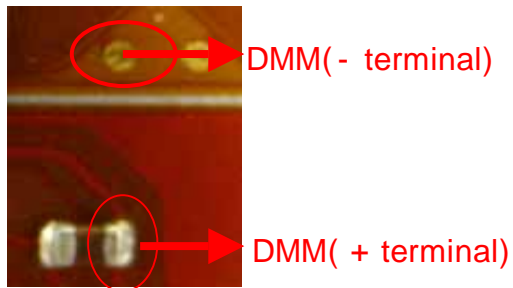
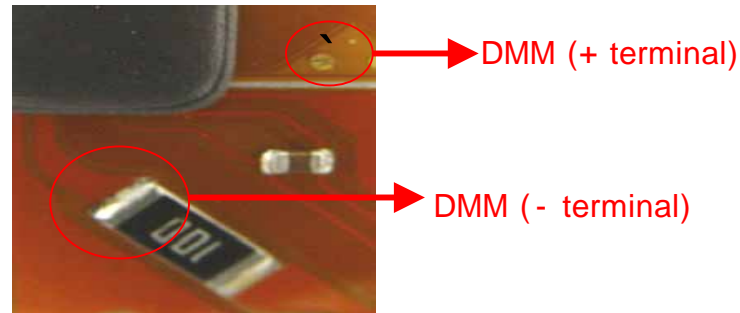

Fig. 2



4. Trouble shooting.

3. Ctrl B/D

CTRL B/D supplies video signal to COF. So if there is a bar defect on screen, It may be the ctrl b/d problem.

A flow of address signal

In this figure, we can easily suppose what will be appeared on screen when a specific part failed.

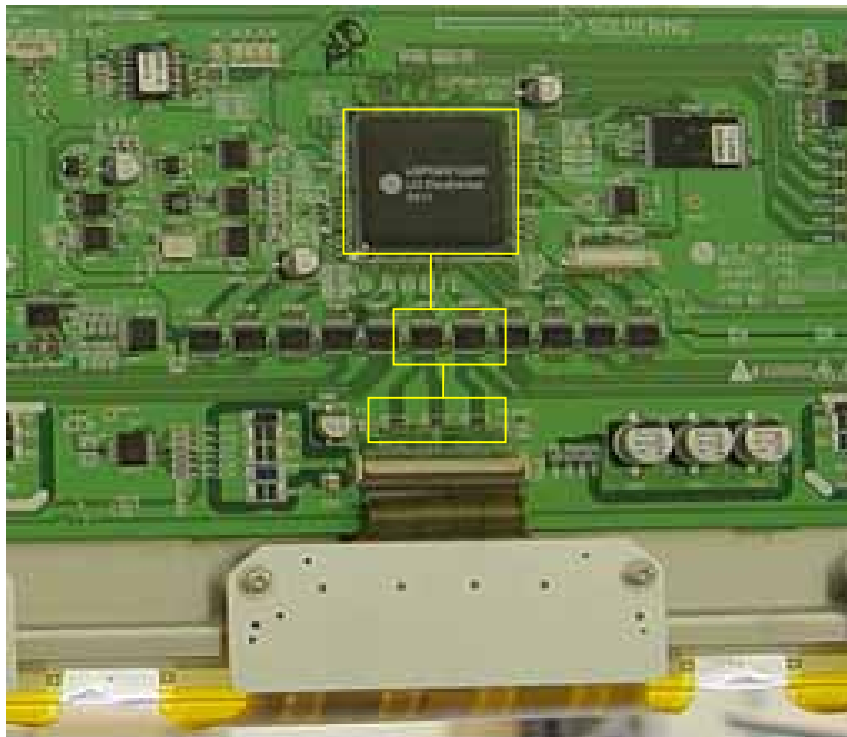

<Diagram of ctrl b/d>

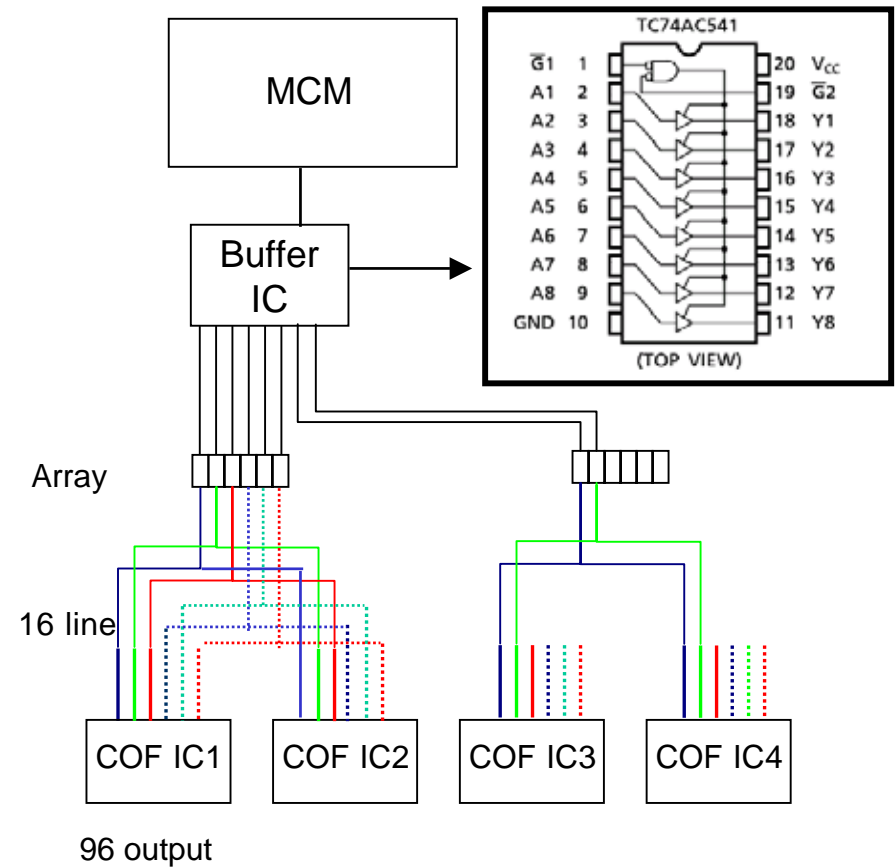

4. Trouble shooting.

• *Vertical defect (line)*

In case of 1 line open or short , check foreign substances in COF connector.

First blow up foreign substances with your mouth. And then if the same line appears, replace the panel.

1 line open or short

This phenomenon is due to COF IC inside short or adherence part of the Film and rear panel electrode problem.
In this case, replace the panel.

1 electrode open

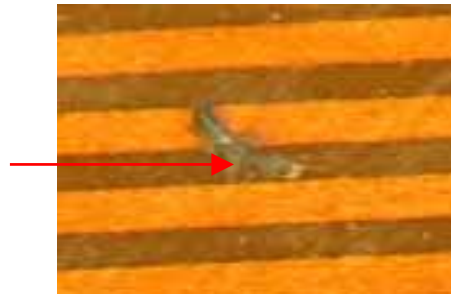

1 line open



Line open or short with same distance.

This is MCM of Ctrl b/d defect. MCM can not be replaced separately. So replace the ctrl b/d.

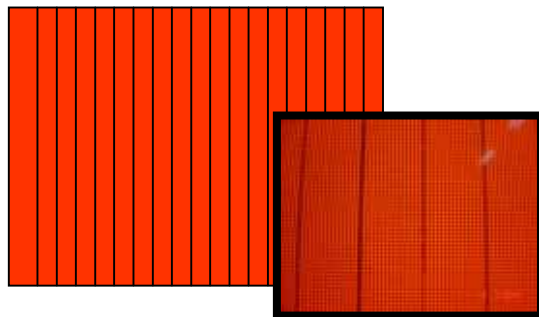

MCM (Multi Chip Module)



4. Trouble shooting.

line defect from each parts

- **Case 1: Buffer IC fail**

COF IC 1,2 192 line(96+96) open.

COF IC 3,4 64 line open (with fixed interval there is on,off Repetition)

16 line open

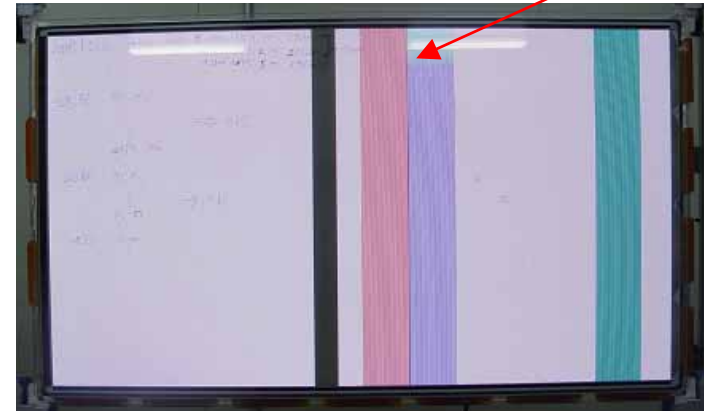

- **case 2 : Array resistor fail**

COF IC1 16 line , COF IC2 16 line open

- **case3 : COF IC fail**

96 line open.

96 line open

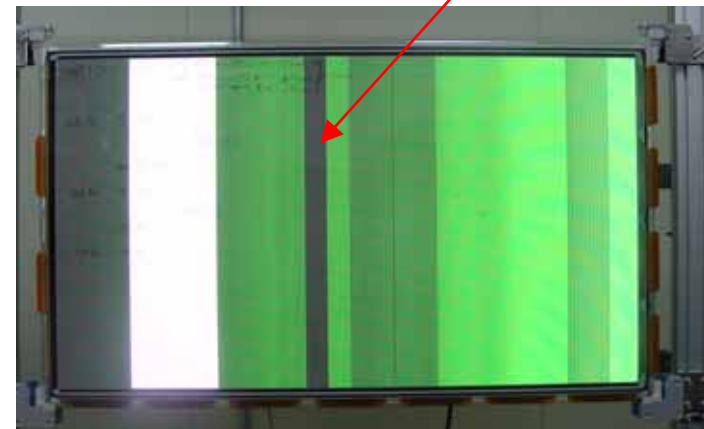

4. Trouble shooting.

• Horizontal (bar)

Most horizontal defects can be repaired. In case of adherence part of the Film and rear panel electrode defect or panel electrode open,short , replace the panel.

1. Connector

It can make a horizontal bar that connector on Y b/d and Z b/d did not plugged well. Because sustain voltage can not be supplied to panel. So check connectors (FPC, Y drv –Y drv) first.

Disconnected

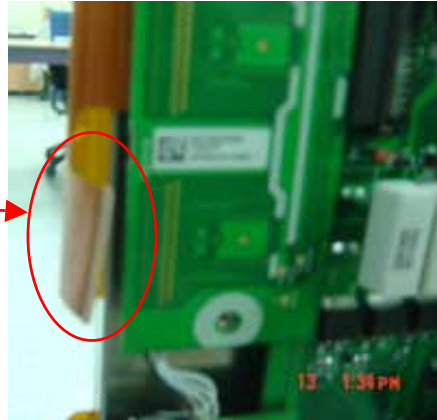

Disconnected

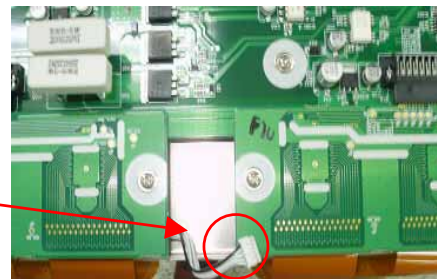

Horizontal bar

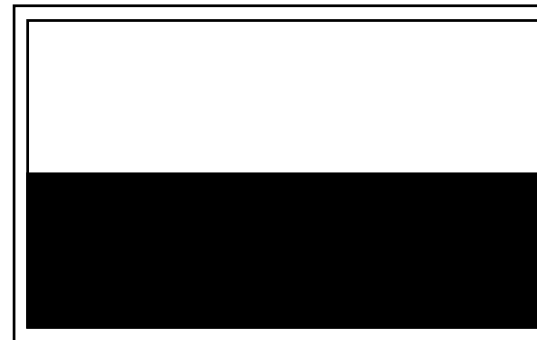

Screen off

4. Trouble shooting.

2. Scan IC check

Check diode value of the right side part of output pin.



Normal diode value. (in case of Panasonic IC=1.035)



Defect diode value= 0.018

* It can be different from each IC Maker. (in case of TI IC= 0.6~0.7)

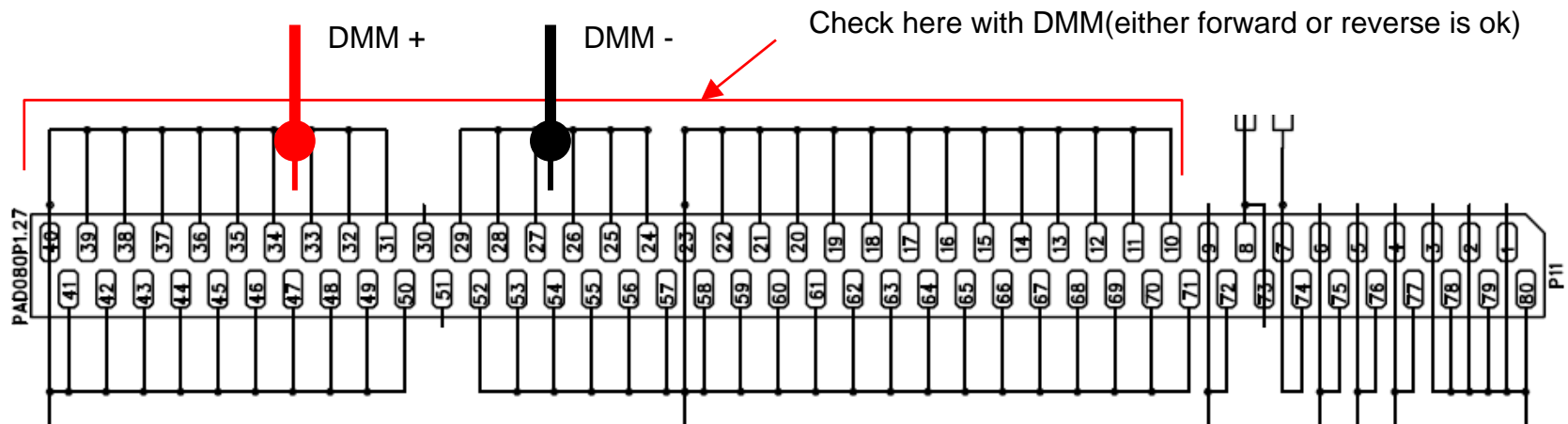

4. Trouble shooting.

• *Horizontal (line)*

1. Check FPC

In case of horizontal 1 or more line, it is due to FPC or panel inside .
ctrl b/d, Y b/d is just normal.

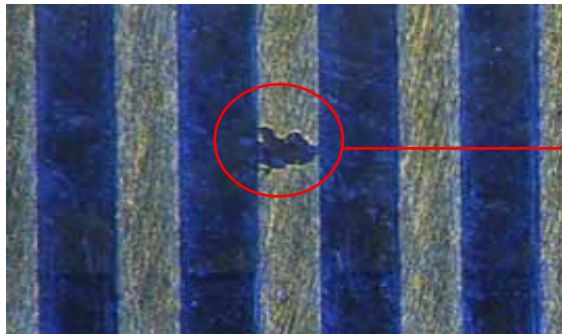

FPC electrode open



Panel electrode
Insulation break down



Horizontal 1 line.

2. Check scan IC

Check with same method that presented in Horizontal (bar).

4. Trouble shooting.

How to check IPM

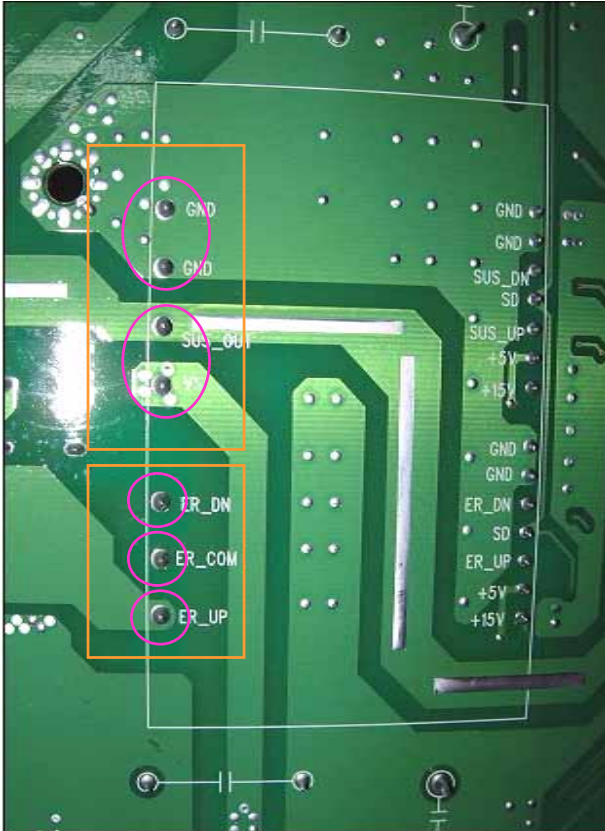

Forward : test 1 GND(+) , Sus-out(-)
2 Sus-out(+),Vs(-)
3 ER-DN(-),ER-COM(+)
4 ER-COM(-),ER-UP(+)

when each 4 TEST Diode value is over 0.4V => **OK**

Reverse : test 1 GND(-) , Sus-out(+)
2 Sus-out(-),Vs(+)
3 ER-DN(+),ER-COM(-)
4 ER-COM(+),ER-UP(-)

when each 4 nodes TEST Diode value is infinity => **OK**





Specially, the value of ER-UP,COM,DN in the Y/Z board, should be checked all of them. but, the terminal of Vs,Sus-out,GND, we must aware to know after check one of IPM because it is parallel.

→ if no problems, check 15V(Y,Z B/D) with GND, → Forward value 0.3V,
Reverse value infinite. If no problems,

42TD1 SPARE PART LIST

NO.	Item no	Description/Specification (English)	Picture
1	E6205-001003	DISPLAY PDP LG-V6 42" W/FILTER AC LINE	







PCB & WIRE & SPEAKER

NO.	Item no	Description/Specification (English)	Picture
1	E7801-043004	PCB ASSY TUNER/V/AUDIO POWER (FOR USA)	
2	E7801-043006	PCB ASSY VGA/DVI (FOR USA)	
3	771-42D101-01	KEY PCB ASSY	
4	771-42D102-01	SPK JACK PCB ASSY	

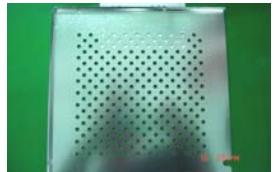

5	771-42D103-01	REMOTE RECEIVE PCB ASSY	
6	E3421-926004	WIRE ASSY 1H2.5-2H2.5 L270 12P/2=7=12P	
7	E3421-926006	WIRE ASSY TJC3-4Y/AMP-4Y/210 FOR SOUND	
8	774P42D101-01	POWER ASSY PDP42	
9	E4850-003001	SPEAKER SUB(FOR 42TD1) 16 OHM 7W R	
10	E4850-004001	SPEAKER SUB (FOR 42TD1) 16 OHM 7W L	
11	E3421-925011	WIRE ASSY L=100MM 10PIN FOR MAIN/AUDIO PCB	
12	E3421-926007	WIRE ASSY 1H2.5-2H2.5 L330 31P (LVDS W-EMI) BIDA	
13	E4406-068001	EMI FILTER CTCR-0930-1B FOR 42PDP	

14	E4406-069001	EMI FILTER CTNF-100B FOR 42PDP	
----	--------------	--------------------------------	--







MECHANICAL PARTS

1	436-42D101-01	BACK TERMINAL SHEET 42D1	
2	483-42D101-01	SHIELD COVER A 42D1	
3	483-42D102-01	SHIELD COVER B 42D1	
4	367-42D101-01	EDGE SADDLE 14MM 42D1	
5	367-42D102-01	EDGE SADDLE 27MM 42D1	
6	423-42D108-01	PATCH FOR SHIELD BOX 42D1	
7	481-42D111-01	SHIELD BOX FOR MAIN PCB JIAYING	

8	481-42D112-01	SHIELD BOX FOR TUNER PCB JIAYING	
9	457-42D101-01	CLAMP ID=4.3MM L=55MM	
10	E3403-004001	TUBE SUMITUBE D5.0 BLK 600V 125C	
11	423-42D111-01	FILTER SUPPORT BTM 42D1	
12	423-42D112-01	FILTER SUPPORT L&R 42D1	
13	423-42D113-01	FILTER SUPPORT TOP 42D1	
14	423-42D107-01	PANEL PATCH V6 42D1	
15	423-42D10C-01	SUPPORT FOR PW BKT 42D1	
16	402-42D112-01	BACK COVER FOR V6 42D1	

17	423-42D115-01	POWER BKT FOR V5/V6 42D1	
18	423-42D114-01	MAIN BKT FOR V6 42D1	

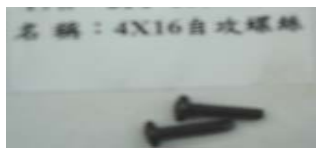
SCREW PARTS







1	602-305006-10	MACH. SCREW WHR 3X6 NIP +H	
2	612-300210-00	S-TAP. SCREW WHR 3X10 A BZN +H	
3	610-300210-10	TS RBD3X10 A NIP +H	
4	614-260208-10	S-TAP. SCREW BIR 2.6X8 A NIP +H	
5	614-400408-10	S-TAP. SCREW BID 4X8 D NIP +H "D"TYPE	
6	614-400416-00	S-TAP. SCREW BID 4X16 D BZN +H	
7	388-42D101-01	PC SHEET FOR KEY PCB 42D1 94V0 0.3mm	

8	388-42D102-01	PC SHEET FOR REMOTE PCB42D1 94V0 0.3mm	
9	326-050010-40	SPONGE CUSHION 500X10X4.0MM W/ADHESIVE	
10	326-095010-40	SPONGE CUSHION 950X10X4.0MM W/AHESIVE	
11	554-080030-01	SHIELD CLOTH 80X30MM W/CONDUCTIVE ADHESIVE KI JD-59	
12	553-024509-40A	SHIELE GASKET 245X9X4.0MM W/CONDUCTIVE ADHESIVE KI JD-60	
13	553-012509-40A	SHIELD GASKET 125X9X4.0MM W/COONDUCTIVE ADHESIVE KI JD-60	
14	553-097009-25A	SHIELD GASKET 970X9X2.5MM W/CONDUCTIVE ADHESIVE KI JD-60	
15	553-054009-25A	SHIELD GASKET 540X9X2.5MM W/CONDUCTIVE ADHESIVE KI JD-60	
16	553-002509-25A	SHIELD GASKET 25X9X2.5MM W/CONDUCTIVE ADHESIVE KI JD-60	
17	553-005009-25A	SHIELD GASKET 50X9X2.5MM W/CONDUCTIVE ADHESIVE KI JD-60	

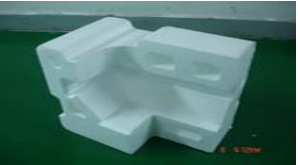
18	610-300210-00	S-TAP. SCREW RND 3X10 A BZN +H	
19	553-004009-40A	SHIELD GASKET 40X9X4.0MM W/CONDUCTIVE ADHESIVE KI JD-60	
20	553-020009-40A	SHIELD GASKET 200X9X40MM W/CONDUCTIVE ADHESIVE KI JD-60	
21	553-017009-25A	SHIELD GASKET 170X9X2.5	
22	60D-407010-40	MACH. SCREW W/SPRING WASHER M4. 0X0.7X10MM WHITE ZINE PLATE	
23	614-400412-00	S-TAP. SCREW BID 4X12 T BZN +H	
24	604-305005-30	MACH. SCREW BID 3X5 BNI +H	
25	361-101261-01	CABLE TIE	
26	601-305008-00	MACH. SCREW CTS 3X8 BZN +H	
27	615-400214-00	SELF-TAPPING SCREW W/BIG WASHER 4X12 BLACK 2N PLATE	







28	604-601020-00	MACHINE SCREW BINDING M6X1.0PX20MM BZN(4334007002)	
----	---------------	--	--

PACKING MATERIAL



1	300-42D101-02C	POLYFOAM FOR MAIN UNIT 42D1 TOP	
2	300-42D102-02C	POLYFOAM FOR MAIN UNIT 42D1 BOTTOM	
3	310-504004-01	POLYBAG EPF 50"X40"X0.04	
4	510-42D101-03K	GIFT BOX TOP ENG 42D1 NIL K	
5	511-42D101-01K	CARTON BOX FOR BTM 42D1	
6	512-42D101-01	SHEET 1160X1160 42D1	

7	512-42D102-01	SHEET 1160X1480	42D1	
---	---------------	-----------------	------	--







COSMETIC

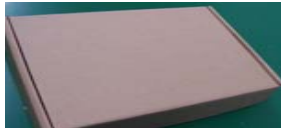

1	263-42D101-01S	POWER LENS	42D1	
2	269-42D101-01L	REMOTE LENS	42D1	
3	277-42D101-01S	FUNCTION KNOB	42D1	
4	244-34B801-01	GIFT BOX HANDLE	34B8	
5	560-42D101-03	MODEL LABEL ENG	42D1 NIL	
6	248-46D201-01	HANDLE FOR PLASMA		
7	568-P46T02-02	WARNING LB ENG	42SF NIL	

8	579-42D103-02	ON/OFF LB ENG	42D1 NIL	
9	563-119-	SERIAL NO. LABEL		
10	200-42D111-03A	FRONT CABINET	42D1 NIL	
11	384-42D101-01	PVC SHEET FOR TUNER BOARD	42D1	
12	384-42D102-01	PVC SHEET FOR MAIN BOARD	42D1	
13	388-42SB02-01H	SPK PLATE MAIN SANSUI 42"	42SB H	
14	388-42SB04-01H	POWER PLATE SANSUI	42SB H	
15	388-42D103-01H	CAUTION PLATE ENG	42D1 H	
16	579-42D102-02	BAR CODE LABEL ESA	42D1	
17	592-42D101-01	TECHNICAL SUPPORT SHEET	ESA 4294LV1 (AI)	

18	579-42D105-01	PROTECTIVE EARTH LABEL FOR ESA 4294LV1	
19	900-42D101-01	PANEL DISPLAY FILTER LG	

ACCESSARY

1	511-42D102-01A	ACCESSORY BOX	
2	590-42D101-02	WARRANTY CARD ENG 42D1 NIL	
3	E7301-010002	BATTERY AAA R03P1.5V <2>	
4	E3404-157001	AC CORD UL 1.88M MET-4D7+SJT 16AWG/3C=MET-202 BETTER	
5	580-42D101-075	INSTRUCTION BOOK E FOR ESA PDP4294LV1	
6	790-003603-A5	ESA REMOTE ASSY ENG 42" TBA	

7	734-BM0205-01	AL BASE FOR 42"&46" W/PACKING USA NIL	
8	740-46D201-02	WALL MOUNTING BRACKET (NON-ROTATE) ASS'Y W/PACKING BLACK ENG	

Exploded View

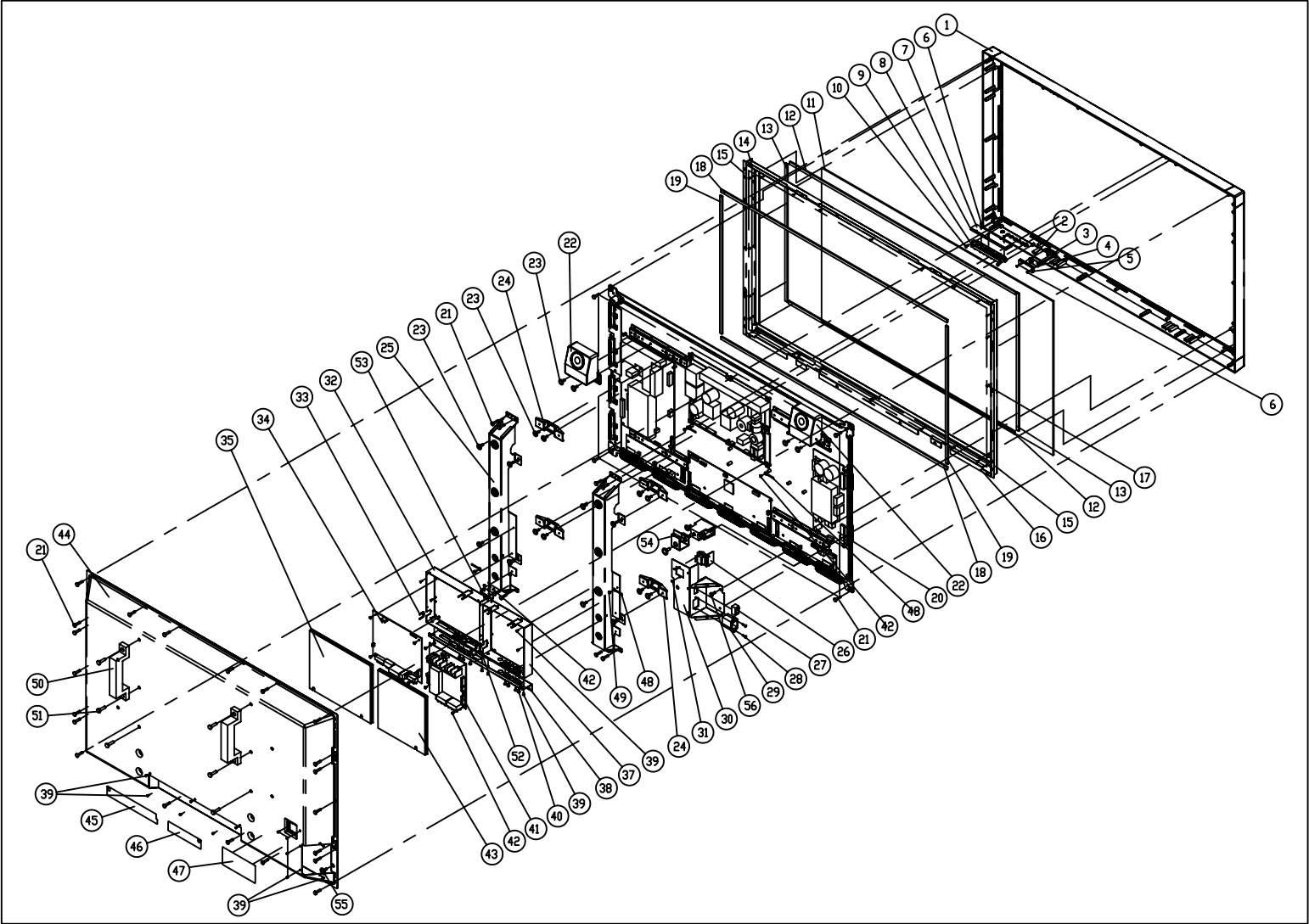

56	614-400412-00	SCREW 4x12	1	
55	615-400412-00	SCREW 4x14	1	
54	423-42D10C-01	SUPPORT FOR PW BKT	1	
53	423-42D108-01	PATCH FOR SHIELD BOX	1	
52	367-42D102-01	EDGE SADDLE 27MM	2	
51	604-601020-00	MACH.SCREW M6x20	4	
50	248-P46U02-01	HANDLE	2	
49	622-302408-10	STP SCREW 3x8	2	
48	23845857	CLAMP	4	
47	560-42D101-01	MODEL PLATE	1	
46	384-42D102-01	PVC SHEET FOR TUNER BOARD	1	
45	384-42D101-01	PVC SHEET FOR MAIN BOARD	1	
44	402-42D10X-01	VACK COVER	1	
43	483-42D102-01	SHIELD COVER B	1	
42	602-305006-10	MACH. SCREW 3x6	14	
41	E7801-043004	TUNER BOARD	1	
40	612-300210-00	STP SCREW 3x10	7	
39	604-305005-630	MACH. SCREW 3x5	22	
38	436-42D101-01	BAK TERMINAL SHEET	1	
37	481-42D102-01	SHIELD BOX B	1	
36				
35	483-42D101-01	SHIELD COVER A	1	
34	E7801-043006	MAIN BOARD	1	
33	367-42D101-01	EDGE SADDLE 14MM	4	
32	481-42D101-01	SHIELD BOX A	1	
31	614-300210-00	STP SCREW 3x10	2	
30	423-42D115-01	POWER BKT FOR V5/V6	1	
29	E4405-035001	AC LINE FILTER	1	
28	601-306008-10	MACH. SCREW 3x8	2	
27	E4101-027001	POWER SWITCH	1	
26	771-42D102-01	AV JACK PCB	1	
25	423-42D114-01	MAIN BKT FOR V6/FORMOSA	2	
24	423-42D107-01	PANEL PATCH FOR V6	4	
23	60D-407010-10	MACH. SCREW W/SP WASHER 4x10	20	
22	E4850-002001	SPK BOX	1	
21	614-400416-00	STP SCREW 4x16	33	
20	E6205-001003	PLASMAS PANEL	1	
19	322-501004-01	CUSHION 500x10x4MM	2	
18	322-951004-01	CUSHION 950x10x4MM	2	
17	610-300210-10	STP SCREW 3x10	22	
16	423-42D101-01	FILTER SUPPORT BTM	1	
15	423-42D102-01	FILTER SUPPORT L&R	2	
14	423-42D103-01	FILTER SUPPORT TOP	1	
13	559-500925-01	SHIELD GASKET 500x9x2.5MM	2	
12	559-950925-01	SHIELD GASKET 950x9x2.5MM	2	
11	900-42D101-01	DISPLAY FILTER LG	1	
10	614-400480-10	STP SCREW 4x8	2	
9	277-42D101-XXS	FUNCTION KNOG	5	
8	771-42D101-01	KEY PCB	1	
7	388-42D101-01	PC SHEET FOR KEY PCB	1	
6	614-260208-10	STP SCREW 2.6x8	5	
5	388-42D102-01	PC SHEET FOR REMOTE PCB	1	
4	771-42D103-01	REMOTE PCB	1	
3	269-42D101-01L	REMOTE LENS	1	
2	263-42D101-01S	POWER LEN	1	
1	200-42D101-XXS	FRONT CABINET	1	
ITEM	PART NO.	DESCRIPTION	QTY	REMARK

If you forget your V-Chip Password

- Omnipotence V-Chip Password: **363200**.
- Press **MENU Right** button.
- Press **CH+, CH-** or **Up, Down** buttons to highlight "CC-VChip" Control.
- Press **MENU Right** and **Up, Down** buttons to highlight "Change Blocking Password".
- Press **Right** button to pop up "Old Password".
- Use the **Number buttons** (0~9) to enter an omnipotence Password.
- Press **Right** button to confirm and will pop up "Password Change Successful".
- Suggest: Change to your familiar Password again.

Software upgrade

- Connect the RS-232C input jack to an external control device (such as a computer) and software upgrade.

Type of connector; D-Sub 9-pin male

No.	Pin name
1	No connection
2	RXD (Receive data)
3	TXD (Transmit data)
4	DTR (DTE side ready)
5	GND
6	DSR (DCE side ready)
7	RTS (Ready to send)
8	CTS (Clear to send)
9	No Connection

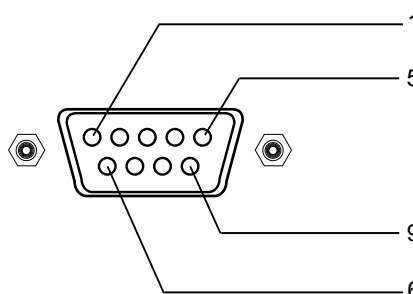

RS-232C configurations

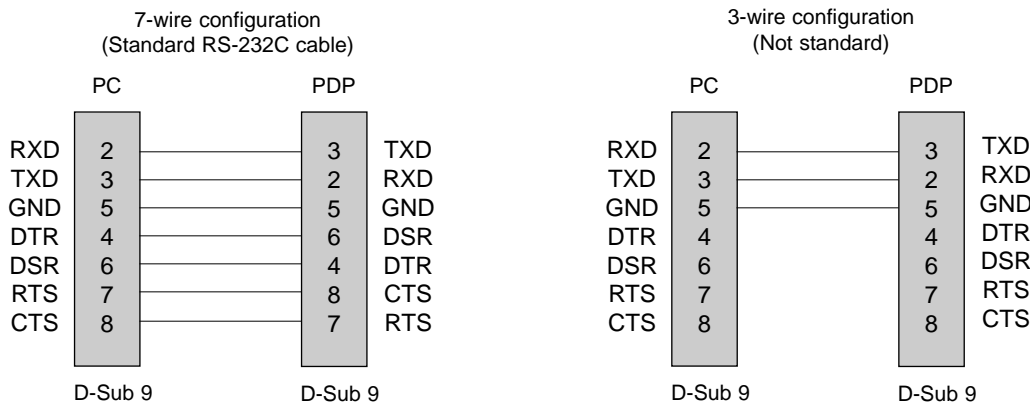

Software upgrade Process

- Power Switch OFF.
- Connect the RS-232 jack of the computer to the RS-232 jack on the plasma back panel. RS-232C connection cables are not supplied with the Plasma.



Computer
RS-232



PDP
RS-232

- Power Switch ON. The power indicator on the front of the panel should now display red, that the Plasma is in standby mode.
- Copy the software (Flash Upgrader) to the computer.
- Open the software (Flash Upgrader.exe)

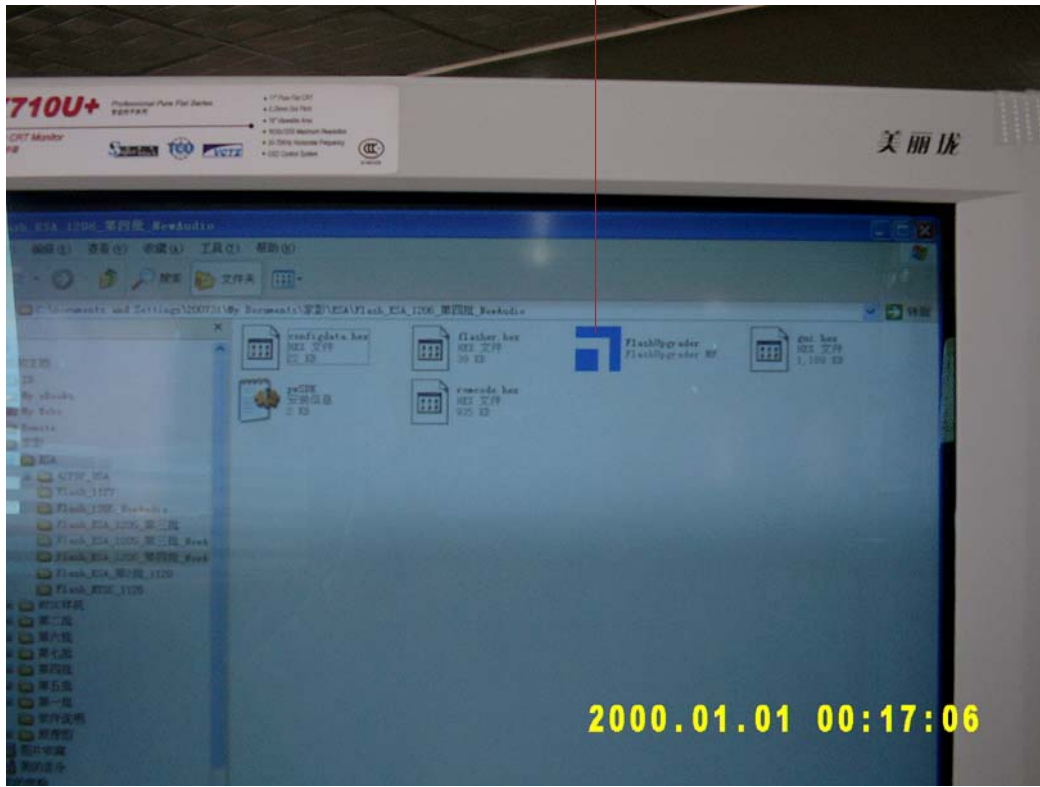

- Point "Flash" on the interface of the Flash Upgrader.exe.

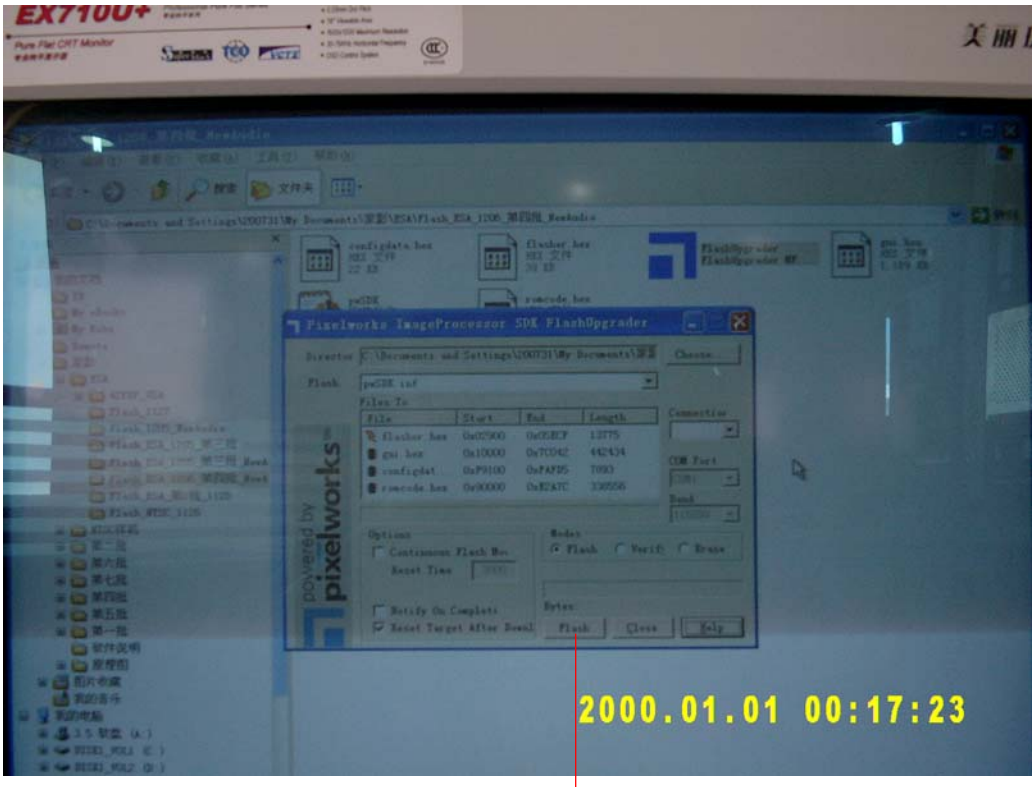

Flash

- Press **STANDBY** button on the front panel or **POWER** button of Remote control, Power indicator is green, the Plasma is in power ON mode, software start upgrader immediately.

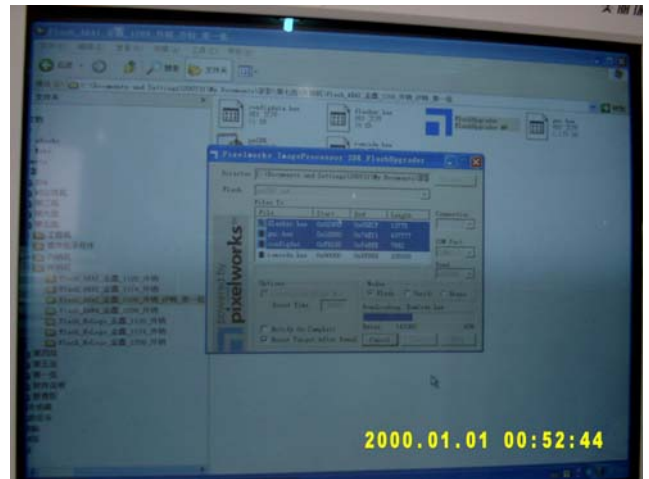
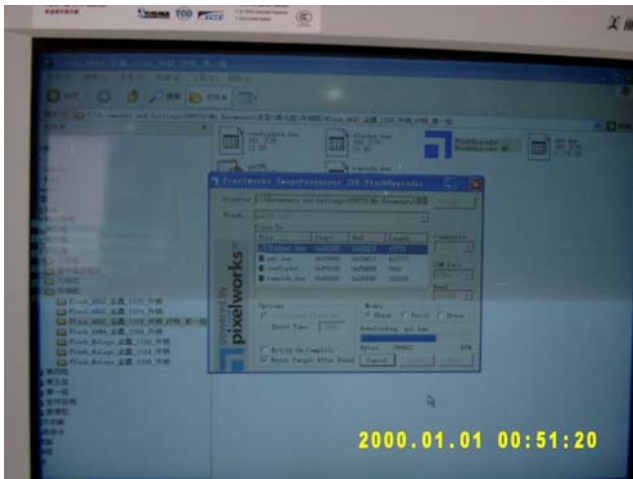

- **Hard Rest** after the upgrader is finished.
Method: Sequence press **F.WHITE**, **VIDEO**, **I.P.C.** button on the Remote control enter **factory Menu** select "**Misc.**", "**Hard Reset**", press **Menu Left** button to **Hard Reset** is finished.

Misc.

Hard Reset

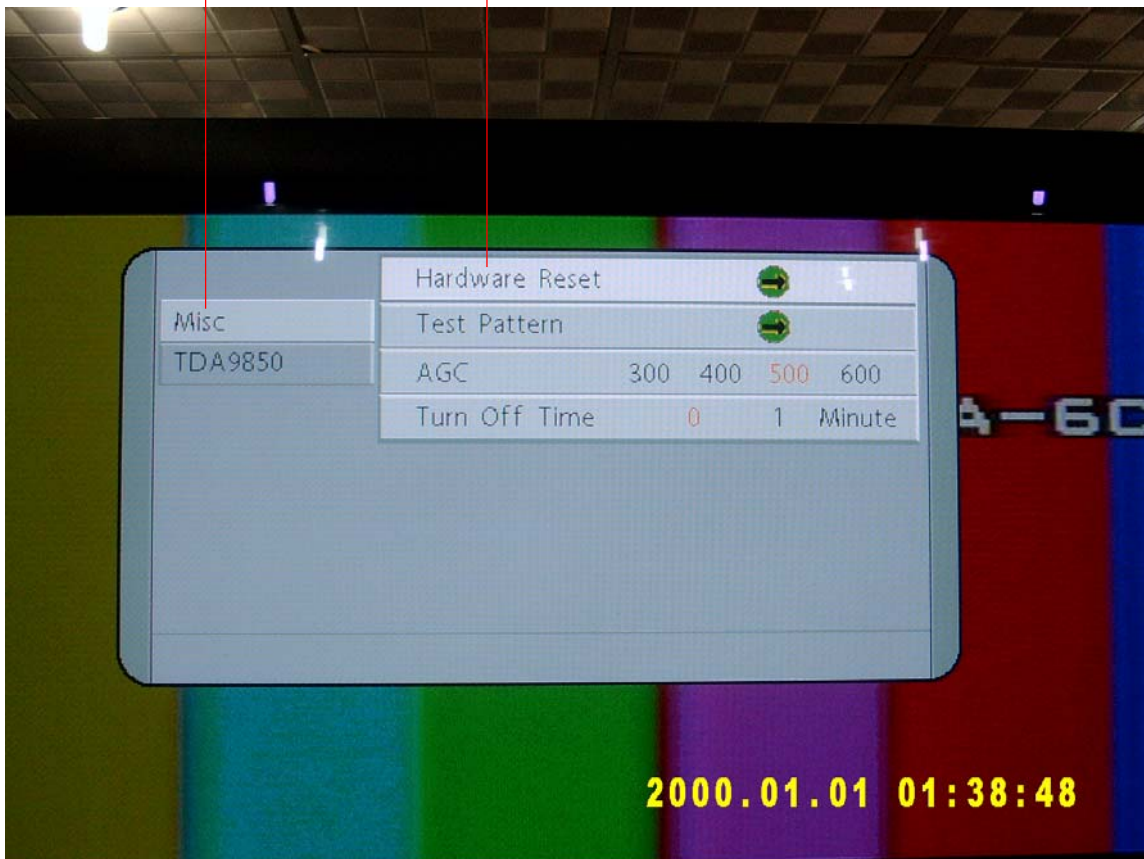

- After the **Hard Reset** is finished, shut down the power switch, take out the RS-232C connection cables after the power indicator is extinguished.

Note: The computer and plasma must be keep **Power ON** in the software upgrade processing.